

Dell PowerEdge XE9640

Technical Guide

Notes, cautions, and warnings

 **NOTE:** A NOTE indicates important information that helps you make better use of your product.

 **CAUTION:** A CAUTION indicates either potential damage to hardware or loss of data and tells you how to avoid the problem.

 **WARNING:** A WARNING indicates a potential for property damage, personal injury, or death.

Chapter 1: System overview	5
Air and Liquid Cooling Infrastructure Requirements	5
New technologies	6
Key workloads	7
Chapter 2: System features	8
Chapter 3: Chassis views and features	10
Chassis views	10
System configurations - front view for PowerEdge XE9640	10
System configurations - rear view for PowerEdge XE9640	11
System configurations - inside view for PowerEdge XE9640	12
Quick Resource Locator for PowerEdge XE9640 system	13
Chapter 4: Processor	14
Processor features	14
Supported processors	14
Chapter 5: Memory subsystem	15
Supported memory	15
System memory guidelines	16
General memory module installation guidelines	18
Chapter 6: Storage	19
Boot Optimized Storage Solution (BOSS)	19
BOSS feature matrix	19
BOSS-N1	19
Datasheets	20
BOSS User Guides	20
Chapter 7: Networking	21
Overview	21
OCP 3.0 support	21
Supported OCP cards	21
OCP NIC 3.0 vs. rack Network Daughter Card comparisons	22
OCP form factors	22
Chapter 8: PCIe subsystem	24
PCIe slot mechanical compatibility matrix	24
Slot priority matrix	24
Chapter 9: Power, thermal, and acoustics	25
Power	25

Power Supply Units.....	26
Thermal.....	26
Thermal design.....	26
Thermal restriction matrix.....	27
Acoustics.....	28
Acoustical design.....	28
PowerEdge XE9640 acoustics.....	28
PowerEdge acoustical dependencies.....	36
Chapter 10: Rack, rails, and cable management.....	37
Rails and cable management information.....	37
Chapter 11: Operating Systems and Virtualization.....	44
Supported operating systems.....	44
Chapter 12: Dell OpenManage Systems Management.....	45
Integrated Dell Remote Access Controller (iDRAC).....	45
Systems Management software support matrix.....	46
Chapter 13: Appendix A. Standards compliance.....	48
Chapter 14: Appendix B: Additional resources.....	49
Customer kits.....	49
Dell Upgrades.....	49
Upgrades portfolio.....	49
Upgrades reference links.....	50
Documentation.....	50
Chapter 15: Appendix C: Additional specifications.....	51
Chassis dimensions.....	51
System weight.....	51
Video specifications.....	52
USB ports specifications.....	53
PSU rating.....	53
Environmental specifications.....	53
Chapter 16: Appendix D: Service and support.....	55
Default support levels.....	55
Default deployment levels.....	55
Other services and support information.....	55
Dell deployment services.....	55
Dell custom deployment Services.....	59
Dell Residency Services.....	59
Dell Data Migration Services.....	59
Dell Enterprise Support Services.....	60

System overview

The Dell PowerEdge XE9640 is a 2-socket, 2U standard depth Intel based server that supports Intel Tuscany 4-GPU baseboard CBB (Moss-I) cold plate module containing 4 Intel Data Center GPU Max Series 1550 OAM GPU module (Gen5 devices) and NVIDIA 4-GPU baseboard Switch board (Moss-N) cold plate module.

The system features:

- Two 4th Generation Intel Xeon Scalable (Intel Sapphire Rapids (Socket E)) Processor (up to 56C/350 W)
- Up to 32 DDR5 RDIMM (registered DIMM) slots
- Up to 4 PCIe slots (4 x16 Gen5)
- Up to 4 x 2.5-inch NVMe SSD drives, 61.44 TB max for XE9640 Intel GPU and NVIDIA GPU supported systems

i **NOTE:** Maximum DIMM transfer speed support dependent on CPU SKU and DIMM population.

Topics:

- [Air and Liquid Cooling Infrastructure Requirements](#)
- [New technologies](#)
- [Key workloads](#)

Air and Liquid Cooling Infrastructure Requirements

The XE9640 has CPUs and GPUs (and a few other minor components) direct liquid cooled 100% of the time while other components like DDR5 DIMMs, PCIe cards, PSUs and storage are air cooled with a max inlet air temperature of 35C.

Water inlet temperature requirement may vary based on several factors on a given deployment. Guidance is that we require 32C primary water temperature but it may be possible to go higher under certain circumstances. CoolIT engagement is required for the final answer on your configuration.

Every XE9640 sale requires the Dell sales team, customer and Cool IT to come together and ensure the environment is ready. For sites that have no water in their data center, this can be a 6 month long process or more. For customers who already have chilled water it may be a shorter engagement, but lead times on rack components for liquid cooling may still be long. A successful XE9640 opportunity is one where the Dell sales team engages Cool IT early to assess the situation, and where the sales team stays engaged with knowledge of the final BOM lead times so the liquid-cooling related PO's can be placed and installation complete in time to support the arrival of the actual servers.

For every XE9640 sale, **dell_salessupport@coolitsystems.com** should be engaged to build a quote or at least ensure liquid cooling capacity is sufficient in any existing environment (for instance if you were trying to add an additional server to an existing rack of XE9640's. Still needs Cool IT blessing on available capacity!)

Liquid cooling components in a datacenter include facility water, cooling distribution units (CDU) and rack manifolds (looks like a PDU but for water). The XE9640 has a higher flow-rate requirement than the rest of PowerEdge 16G platforms. As such, the rack manifold is not shared with the other platforms.

The rack manifold model numbers from Cool IT that are supported with the 42U XE9640 rack manifold and 48U XE9640 rack manifold. Each can handle a full rack of each size.

The CDU's (Cooling distribution units) available from Cool IT that are supported with the XE9640 are the in-rack CHx80 and CHx200 models, as well as the end-of-row CHx750 which is generally chosen for multi-rack liquid cooling XE9640 environments. Each model number is indicative of the total number of kilowatts of cooling capacity, however there are many variables (T-case of CPUs in your server configuration, flow rate of chilled facility water, temperature of water inlet from facility, etc) and sales must always engage Cool IT for sizing and BOM for quoting.

Rack requirements will vary per customer depending on density, number of power supplies per server, PDU choices, and brand preference - however the minimum supportable rack is 750mm wide by 1200mm deep. Standard 600m wide by 1070mm racks are not supported.

Pictured below is a rack full of XE9640 demonstrating an in-rack CDU and the liquid manifold, which always goes on the right side of the rack when facing from the back.

XE9640 Direct Liquid Cooled Rack Example

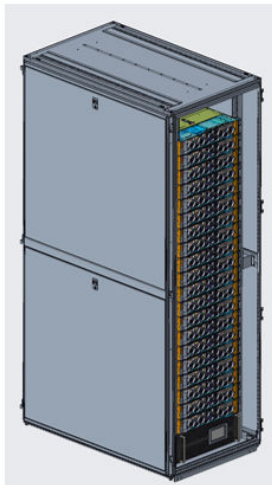

Example Cool IT CHx200 in-rack Cooling Distribution Unit (CDU) shown.

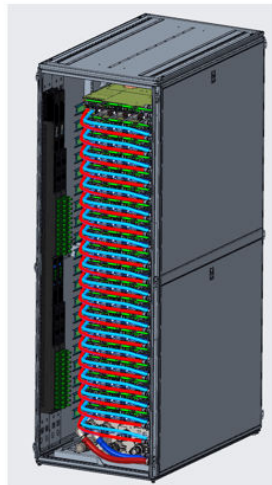

Rack is at least 750mm wide by 1200mm deep, with additional depth potentially dictated by PDU choice and quantity.

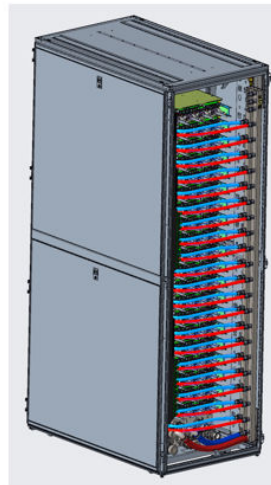

Liquid Manifold goes on the right, always. This manifold is unique for XE9640 due to higher flow rate.

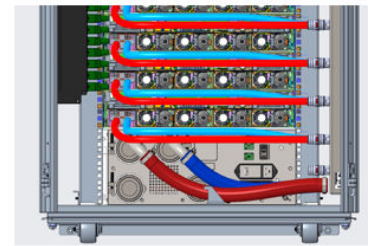

Detail of manifold and in-rack CDU. End of row CDU (CHx750) likely to be used for large deployments.

Figure 1. Direct Liquid Cooled Racks

New technologies

Table 1. New technologies

Technology	Detailed Description
4th Generation Intel Xeon Scalable (Intel Sapphire Rapids) Processor (Socket E)	Core count: Up to 56 core per processor
	UPI speed: Up to 4 x UPIs/socket @ 16 GT/s or 20 GT/s
	Maximum number of PCIe lanes: Integrated 80 PCIe 5.0 lanes @ 32 GT/s PCIe Gen5
	Maximum TDP: 350 W
4800 MT/s DDR5 Memory	<ul style="list-style-type: none"> Only 16 DIMM slots are supported out of 32 DIMMs (with 8 DIMMs per processor) for XE9640 Intel GPU supported systems 8 DIMMS, 16DIMMs and 32DIMMs for XE9640 NVIDIA GPU supported systems
	Supports RDIMM@4800MT/s (1DPC), 4400MT/s (2DPC) i NOTE: XE9640 supports RDIMM only
Flex I/O	1 GbE x LOM board (optional)
	Rear I/O with: <ul style="list-style-type: none"> 1 GbE Dedicated Management Network Port USB 3.0 x1 USB 2.0 x1
	Serial port option
	OCP Mezz 3.0 (supported by x8 PCIe lanes)
	Front I/O with:

Table 1. New technologies (continued)

Technology	Detailed Description
	<ul style="list-style-type: none"> ● USB 2.0 x1 ● Micro USB x1(optional) ● 1 x VGA
CPLD 1-wire	Supports payload data of Riser, BP and Rear IO to BOSS-N1 and iDRAC
Accelerator GPUs	<ul style="list-style-type: none"> ● Four Intel Data Center Max GPU series 1550 600 W OAM GPUs, fully interconnected with XeLink ● Four NVIDIA H100 700 W SXM GPUs fully interconnected with NVlink, 80 GB and 94 GB
Power Supplies	<p>86 mm dimension is the new PSU form factor design on 16G 54V design</p> <p>Four Titanium 2800 W AC supports two redundancy policies</p> <ol style="list-style-type: none"> 1. 2+0 Non redundant, full power with 2x PSUs 2. 2+1 - N+1 redundancy 3. 2+2 - N+N redundancy 4. Mix PSU source is not recommended. 5. Different brand PSU cannot be mixed in the same chassis

Key workloads

- Scale-out AI ML/DL Training and Inferencing
- HPC Simulation Modeling

System features

The following table shows the features of the PowerEdge XE9640.

Table 2. Features

Features	PowerEdge XE9640
Processors	Two 4th Generation Intel Xeon Scalable processors with up to 56 cores
Memory	DIMM Speed <ul style="list-style-type: none"> Up to 4800 MT/s (1 DPC) Up to 4400 MT/s (2 DPC) Memory Type <ul style="list-style-type: none"> RDIMM Memory module slots <ul style="list-style-type: none"> Only 16 DIMM slots are supported out of 32 DIMMs (with 8 DIMMs per processor) for XE9640 Intel GPU supported systems 8 DIMMs, 16 DIMMs and 32 DIMMs for XE9640 NVIDIA GPU supported systems Supports registered ECC DDR5 DIMM slots Maximum RAM <ul style="list-style-type: none"> Intel GPU: RDIMM max 1TB NVIDIA GPU: RDIMM max 2TB
Storage Controllers	<ul style="list-style-type: none"> Internal Boot: Boot Optimized Storage Subsystem (NVMe BOSS-N1): HWRAID 2 x M.2 SSDs
Drive Bays	Front bays: <ul style="list-style-type: none"> Up to 4 x 2.5-inch NVMe SSD drives, 61.44 TB max for XE9640 Intel GPU and NVIDIA GPU supported systems
Power Supplies	<ul style="list-style-type: none"> 2800 W AC Titanium, 54V
Cooling Options	<ul style="list-style-type: none"> 100%Direct Liquid Cooling (DLC)
Fans	High performance (HPR) Gold fans Four sets of HPR fans
Dimension	Height: 86.8 mm (3.41 inches) Width: 482 mm (18.97 inches) Depth: 926.5 mm (36.47 inches) with bezel 912.8 mm (35.93 inches) without bezel
Form Factor	2U rack server
Embedded Management	<ul style="list-style-type: none"> iDRAC9 iDRAC Direct iDRAC RESTful with Redfish iDRAC Service Module
Bezel	Optional LCD bezel or security bezel
OpenManage Software	<ul style="list-style-type: none"> CloudIQ for PowerEdge plug in OpenManage Enterprise

Table 2. Features (continued)

Features	PowerEdge XE9640
	<ul style="list-style-type: none"> ● OpenManage Enterprise Integration for VMware vCenter ● OpenManage Integration for Microsoft System Center ● OpenManage Integration with Windows Admin Center ● OpenManage Power Manager plugin ● OpenManage Service plugin ● OpenManage Update Manager plugin
Mobility	Not supported
OpenManage Integrations	<ul style="list-style-type: none"> ● BMC TrueSight ● Microsoft System Center ● OpenManage Integration with ServiceNow ● Red Hat Ansible Modules ● VMware vCenter and vRealize Operations Manager ● Terraform Providers
Security	<ul style="list-style-type: none"> ● Cryptographically signed firmware ● Data at Rest Encryption (SEDs with local or external key mgmt) ● Secure Boot ● Secured Component Verification (Hardware integrity check) ● Secure Erase ● Silicon Root of Trust ● System Lockdown (requires iDRAC9 Enterprise or Datacenter) ● TPM 2.0 FIPS, CC-TCG certified, TPM 2.0 China NationZ
Embedded NIC	2 x 1 GbE LOM (optional)
Networking Options	OCP x 8 Mezz 3.0
GPU Options	<ul style="list-style-type: none"> ● four NVIDIA H100 700W SXM GPUs fully interconnected with NVlink ● four Intel Data Center Max GPU series 1550 600W OAM GPUs, fully interconnected with XeLink
Ports	Front Ports <ul style="list-style-type: none"> ● 1 x USB 2.0 ● 1 x iDRAC Direct (Micro-AB USB) port ● 1 x VGA
PCIe	2 CPU configuration: Up to 4 PCIe slots (4 x16 Gen5)
Operating System and Hypervisors	<ul style="list-style-type: none"> ● Canonical Ubuntu Server LTS ● Red Hat Enterprise Linux For specifications and interoperability details, see Dell Enterprise Operating Systems on Servers, Storage, and Networking page at Dell.com/OSsupport .

Chassis views and features

Topics:

- Chassis views
- Quick Resource Locator for PowerEdge XE9640 system

Chassis views

System configurations - front view for PowerEdge XE9640

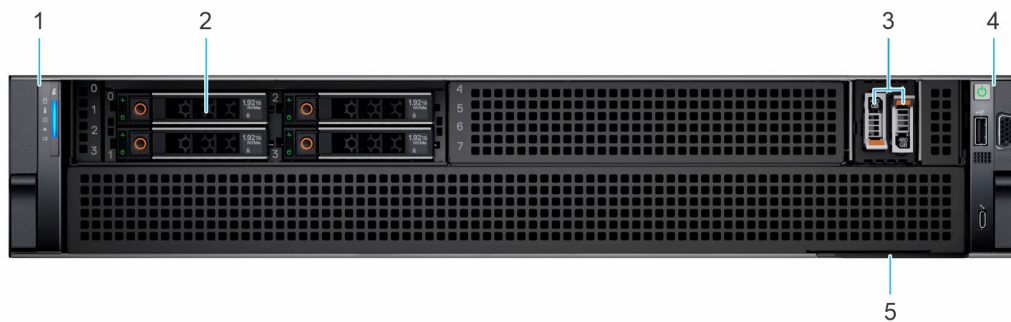

Figure 2. 4 x 2.5-inch NVMe SSD drives for XE9640 Intel and NVIDIA GPU configuration

Table 3. Features available on the front of the 4 x 2.5-inch NVMe SSD drives for XE9640 Intel and NVIDIA GPU configuration

Item	Ports, panels, and slots	Icon	Description
1	Left control panel	N/A	Contains the system health, system ID, and the status LED indicator.
2	Drives	N/A	Enables you to install drives that are supported on your system.
3	BOSS-N1	N/A	There are two M.2 connectors populated on the board and support two NVMe drives for boot.
4	Right control panel	N/A	Contains the power button, USB port, iDRAC Direct (Micro-AB USB) port.
5	Express service tag	N/A	The Express Service Tag is a slide-out label panel that contains system information such as Service Tag, NIC, MAC address, and so on. If you have opted for the secure default access to iDRAC, the Information tag will also contain the iDRAC secure default password.

System configurations - rear view for PowerEdge XE9640

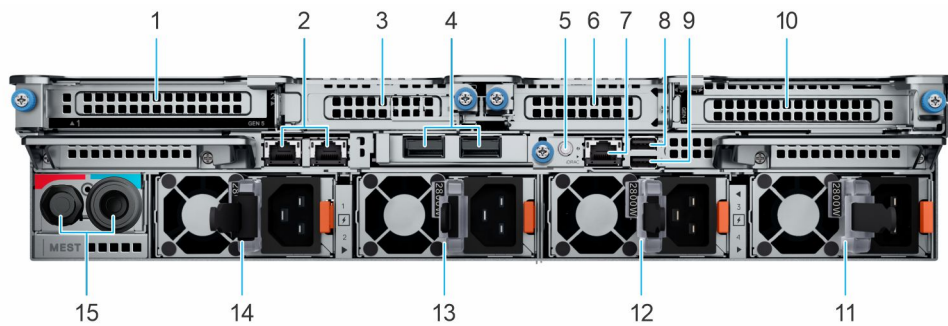

Figure 3. XE9640 chassis rear view

Table 4. Rear view of the system





Item	Ports, panels, or slots	Icon	Description
1	PCIe expansion card riser 1 (slot 1)	NA	The expansion card riser enables you to connect PCI Express expansion cards.
2	NIC Ports		The NIC ports are embedded on the LOM card that is connected to the system board.
3	PCIe expansion card riser 1 (slot 2)	NA	The expansion card riser enables you to connect PCI Express expansion cards.
4	OCP NIC card	N/A	The OCP NIC card supports OCP 3.0. The NIC ports are integrated on the OCP card which is connected to the system board.
5	System Identification (ID) button		<p>The System Identification (ID) button is available on the front and back of the system. Press the button to identify a system in a rack by turning on the system ID button. You can also use the system ID button to reset iDRAC and to access BIOS using the step through mode. When pressed, the system ID LED in the back panel blinks until either the front or rear button is pressed again. Press the button to toggle between on or off mode.</p> <p>NOTE: If the server stops responding during POST, press and hold the System ID button for more than five seconds to enter the BIOS progress mode</p> <p>NOTE: To reset the iDRAC (if not disabled on the iDRAC setup page by pressing F2 during system boot), press and hold the System ID button for more than 15 seconds.</p>
6	PCIe expansion card riser 4 (slot 3)	NA	The expansion card riser enables you to connect PCI Express expansion cards.
7	Dedicated iDRAC9 Ethernet port		Enables you to remotely access iDRAC. For more information, see the Integrated <i>Dell Remote Access Controller User's Guide</i> at www.dell.com/poweredgemanuals .
8	USB 3.0 port		The USB port is 4-pin, 3.0-compliant. This enables you to connect USB devices to the system.
9	USB 2.0 port		The USB port is 4-pin, 2.0-compliant. This port enables you to connect USB devices to the system.
10	PCIe expansion card riser 4 (slot 4)	NA	The expansion card riser enables you to connect PCI Express expansion cards.
11	Power supply unit (PSU) 4	N/A	PSU4 is the fourth PSU of the system.
12	Power supply unit (PSU) 3	N/A	PSU3 is the third PSU of the system.

Table 4. Rear view of the system (continued)

Item	Ports, panels, or slots	Icon	Description
13	Power supply unit (PSU) 2	N/A	PSU2 is the secondary PSU of the system.
14	Power supply unit (PSU) 1	N/A	PSU1 is the primary PSU of the system.
15	Manifold	NA	The Manifold liquid cooling allows cooling for the GPUs and processors.

System configurations - inside view for PowerEdge XE9640

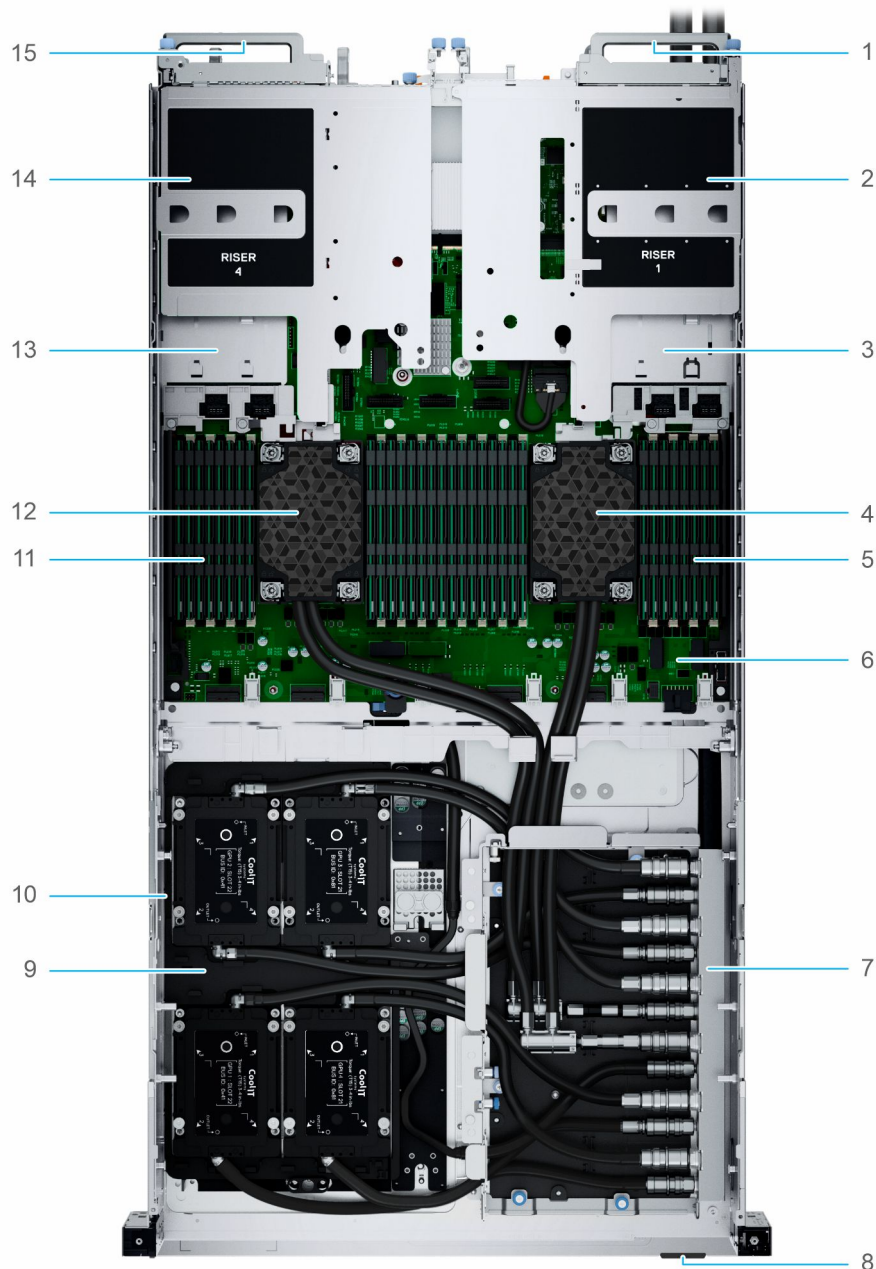

Figure 4. XE9640 with Intel GPUs - inside the system

1. System handle
2. Riser 1
3. VSB
4. Processor 1

5. Memory modules for processor 1
6. System board
7. Manifold Liquid cooling
8. Backplane cover
9. Express service tag
10. GPU board
11. GPU heat sink
12. Memory modules for processor 2
13. Processor 2
14. VSB
15. Riser 4
16. System handle

Quick Resource Locator for PowerEdge XE9640 system

Processor



Topics:

- [Processor features](#)

Processor features

The Intel 4th Generation Xeon® Scalable Processors stack is the next generation data center CPU offering with significant performance increases, integrated acceleration, and next generation memory and I/O. Sapphire Rapids will accelerate customer usages with unique workload optimizations.

The following lists the features and functions included in the Sapphire Rapids offering:

- Faster UPI with up to 4 Intel Ultra Path Interconnect (Intel UPI) at up to 16GT/s, increasing multi-socket bandwidth
- More, Faster I/O with PCI Express 5 and up to 80 lanes (per socket)
- Enhanced Memory Performance with DDR5 support and memory speed up to 4800 MT/s (1DPC) and 4400 MT/s (2DPC)
- New built-in accelerators for data analytics, networking, storage, crypto, and data compression

Supported processors

Table 5. Supported Processors for XE9640

Processor	Clock Speed (GHz)	Cache (M)	UPI (GT/s)	Cores	Threads	Turbo	Memory Speed (MT/s)	Memory Capacity	CPS Enabled	TDP
8480+	2	105	16	56	112	Turbo	4800	6 TB	Y	350 W
8470Q	2.1	105	16	52	104	Turbo	4800	6 TB	Y	350 W
8470	2	105	16	52	104	Turbo	4800	6 TB	Y	350 W
8468	2.1	105	16	48	96	Turbo	4800	6 TB	Y	350 W
8460Y+	2	105	16	40	80	Turbo	4800	6 TB	Y	300 W
8452Y	2	68	16	36	72	Turbo	4800	6 TB	Y	300 W

Memory subsystem

Topics:

- Supported memory
- System memory guidelines
- General memory module installation guidelines

Supported memory

Table 6. Memory technology comparison

Feature	PowerEdge XE9640 (DDR5)
DIMM type	RDIMM
Transfer speed	4800 MT/s (1DPC), 4400 MT/s (2DPC)
Voltage	1.1 V

i **NOTE:** Maximum DIMM transfer speed support dependent on CPU SKU and DIMM population.

The following table lists the supported DIMMs for the XE9640.

Table 7. Supported DIMMs for Intel GPUs

DIMM Speed (MT/s)	DIMM Type	DIMM Capacity (GB)	Ranks per DIMM	Data Width	DIMM Volts (V)
4800	RDIMM	64	2	x4	1.1

Table 8. Supported DIMMs for NVIDIA GPUs

DIMM Speed (MT/s)	DIMM Type	DIMM Capacity (GB)	Ranks per DIMM	Data Width	DIMM Volts (V)
4800	RDIMM	16	1	x8	1.1
4800	RDIMM	32	2	x8	1.1
4800	RDIMM	64	2	x4	1.1

Table 9. Total System Memory Capacity Requirement for Intel GPUs

DIMM capacity	64 GB
16 x DIMM sockets population	Total memory: 1 TB

Table 10. Total System Memory Capacity Requirement for NVIDIA GPUs

DIMM capacity	16 GB			32 GB			64 GB		
	Total memory	80 GB GPU	90 GB GPU	Total memory	80 GB GPU	90 GB GPU	Total memory	80 GB GPU	90 GB GPU
8 x DIMM	64 GB	Not supported	Not supported	256 GB	Not supported	Not supported	512 TB	Support	Support

Table 10. Total System Memory Capacity Requirement for NVIDIA GPUs (continued)

DIMM capacity	16 GB			32 GB			64 GB		
sockets population									
16 x DIMM sockets population	256 GB	Not supported	Not supported	512GB	Support	Support	1 TB	Support	Support
32 x DIMM sockets population	512 GB	Support	Support	1 TB	Support	Support	2 TB	Support	Support

System memory guidelines

The PowerEdge XE9640 system supports DDR5 registered DIMMs (RDIMMs). System memory holds the instructions that are started by the processor.

For Intel GPU configured systems: Your system memory is organized into eight channels per processor (two memory sockets per channel), 16 memory sockets per processor and 32 memory sockets per system.

For NVIDIA GPU configured systems: Your system memory is organized into 16 channels per processor (two memory sockets per channel), 32 memory sockets per system.

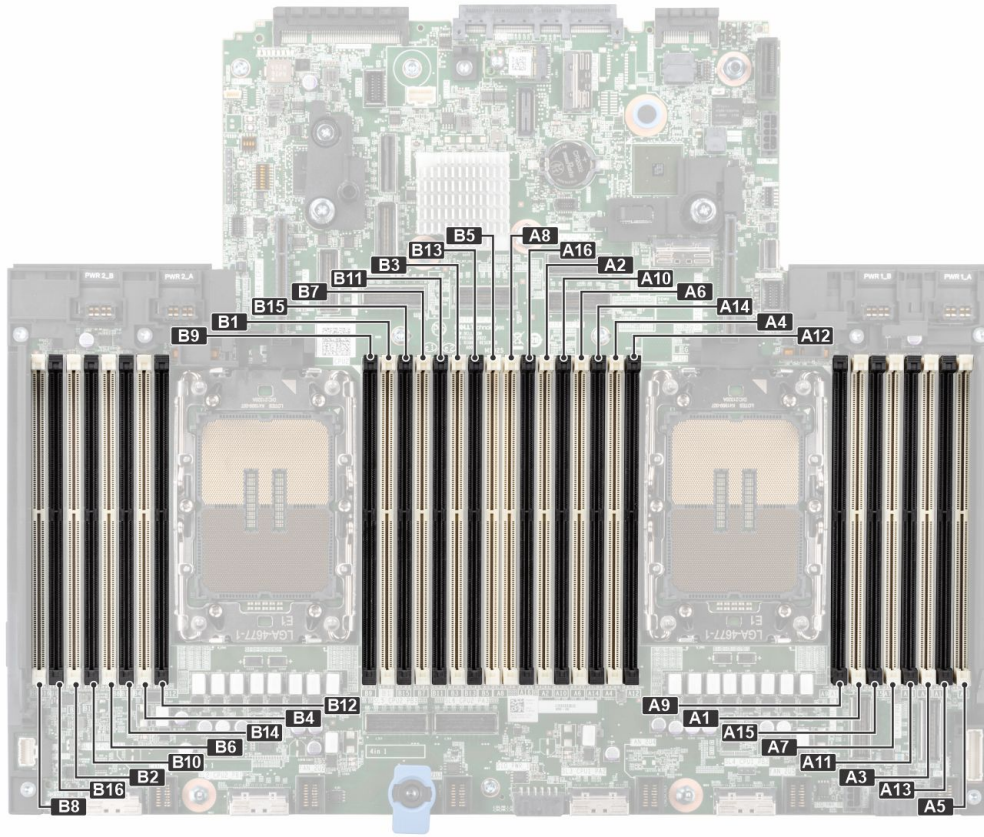

Figure 5. Memory channels

Memory channels are organized as follows:

Table 11. Memory channels

Processor	Channel A	Channel B	Channel C	Channel D	Channel E	Channel F	Channel G	Channel H
Processor 1	Slots A1 and A9	Slots A7 and A15	Slots A3 and A11	Slots A5 and A13	Slots A4 and A12	Slots A6 and A14	Slots A2 and A10	Slots A8 and A16
Processor 2	Slots B1 and B9	Slots B7 and B15	Slots B3 and B11	Slots B5 and B13	Slots B4 and B12	Slots B6 and B14	Slots B2 and B10	Slots B8 and B16

Table 12. Supported memory matrix for Intel GPUs

DIMM type	Rank	Capacity	DIMM rated voltage and speed	Operating Speed	
				1 DIMM per channel (DPC)	2 DIMMs per channel (DPC)
RDIMM	2 R	64 GB	DDR5 (1.1 V), 4800 MT/s	4800 MT/s	4400 MT/s

Table 13. Supported memory matrix for NVIDIA GPUs

DIMM type	Rank	Capacity	DIMM rated voltage and speed	Operating Speed	
				1 DIMM per channel (DPC)	2 DIMMs per channel (DPC)
RDIMM	1 R	16 GB	DDR5 (1.1 V), 4800 MT/s	4800 MT/s	4400 MT/s

Table 13. Supported memory matrix for NVIDIA GPUs (continued)

DIMM type	Rank	Capacity	DIMM rated voltage and speed	Operating Speed	
				1 DIMM per channel (DPC)	2 DIMMs per channel (DPC)
	2 R	32 GB, 64 GB	DDR5 (1.1 V), 4800 MT/s	4800 MT/s	4400 MT/s

NOTE: The processor may reduce the performance of the rated DIMM speed.

NOTE: Maximum DIMM transfer speed support dependent on CPU SKU and DIMM population.

General memory module installation guidelines

To ensure optimal performance of your system, observe the following general guidelines when configuring your system memory. If your system's memory configuration fails to observe these guidelines, your system might not boot, stop responding during memory configuration, or operate with reduced memory.

The memory bus may operate at speeds of 4800 MT/s depending on the following factors:

- System profile selected (for example, Performance, Performance Per Watt Optimized (OS), or Custom [can be run at high speed or lower])
- Maximum supported DIMM speed of the processors
- Maximum supported speed of the DIMMs

NOTE: MT/s indicates DIMM speed in MegaTransfers per second.

The following are the recommended guidelines for installing memory modules:

- All DIMMs must be DDR5.
- If memory modules with different speeds are installed, they operate at the speed of the slowest installed memory module(s).
- Populate memory module sockets only if a processor is installed.
 - For Intel GPU configured with dual-processor systems, sockets A1 to A8 and sockets B1 to B8 are available.
 - For NVIDIA GPU configured with dual-processor systems, sockets A1 to A16 and sockets B1 to B16 are available.
- In **Optimizer Mode**, the DRAM controllers operate independently in the 64-bit mode and provide optimized memory performance.

Table 14. Memory population rules for Intel GPUs

Processor	Memory population	Memory population information
Dual processor (Start with processor1. Processor 1 and processor 2 population should match)	A{1}, B{1}, A{2}, B{2}, A{3},B{3}, A{4}, B{4}, A{5}, B{5},A{6}, B{6}, A{7}, B{7} A{8},B{8}	16 DIMMs are supported per system.

Table 15. Memory population rules for NVIDIA GPUs

Processor	Memory population	Memory population information
Dual processor (Start with processor1. Processor 1 and processor 2 population should match)	A{1}, B{1}, A{2}, B{2}, A{3},B{3}, A{4}, B{4}, A{5}, B{5},A{6}, B{6}, A{7}, B{7} A{8},B{8}, A{9}, B{9}, A{10},B{10}, A{11}, B{11}, A{12}, B{12}, A{13}, B{13}, A{14},B{14}, A{15}, B{15}, A{16},B{16}	8 or 16 or 32 DIMMs are supported per system.

- Populate all the sockets with white release tabs first, followed by the sockets with black release tabs.
- Mixing of any different memory module capacities is not supported.

Storage

Topics:

- [Boot Optimized Storage Solution \(BOSS\)](#)

Boot Optimized Storage Solution (BOSS)

BOSS is a RAID solution that is designed to boot operating systems and segregate operating system boot drives from data on server-internal storage.

BOSS feature matrix

Table 16. BOSS feature matrix

BOSS card	Drive Size	RAID levels	Stripe size	Virtual disk cache function	Maximum number of virtual disks	Maximum number of drives supported	Drive types	PCIe support	Disk cache policy	Support for Non-RAID disks	Cryptographic digital signature to verify firmware payload	Hot Plug
BOSS-N1 Monolithic	M.2 devices are read-intensive with 480 GB capacity	RAID1 and RAID0	Supports default 64K stripe size only	None	1	2	M.2 NVMe SSDs	Gen3	Drive default	No	Yes	Yes

BOSS-N1

BOSS-N1 is offered as a means of booting 16G servers to a full OS when the target OS is a full OS (not just a hypervisor), or the user does not wish to trade off standard hot plug drive slots for OS install

The HW RAID BOSS-N1 card is a RAID controller with a limited feature set that presents M.2 NVMe-only SSDs as either a RAID 0 disk or a single RAID1 volume with 2 disks. BOSS-N1 enables support for 480bGB Disks from Factory Install.

Hardware: BOSS-N1 Controller and Carrier (x2)

Reliability: Enterprise-Class M.2 NVMe SSDs

Supports dual 80 mm, Read Intensive (1DWPD), M.2 devices 480 GB

Accessibility: Internal Riser card

Serviceability: Internal replacement

Supports Hardware RAID1 and RAID0

Supports UEFI boot

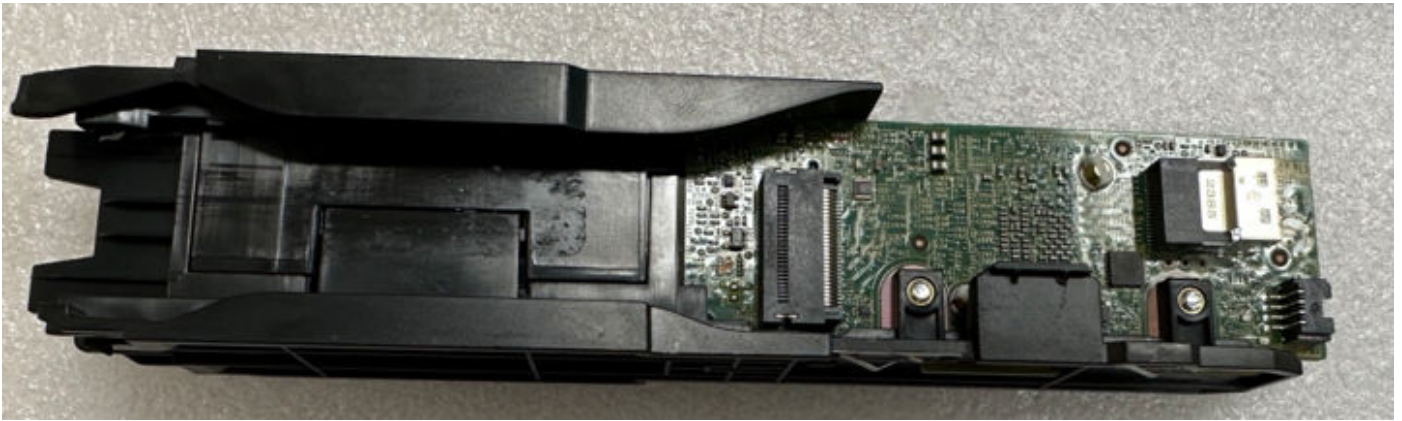

Figure 6. BOSS_N1 Modular SSD assembly

Datasheets

- [BOSS-N1](#)

BOSS User Guides

- [BOSS-N1](#)

Networking

Topics:

- [Overview](#)
- [OCP 3.0 support](#)

Overview

PowerEdge offers a wide variety of options to get information moving to and from our servers. Industry best technologies are chosen, and systems management features are added by our partners to firmware to tie in with iDRAC. These adapters are rigorously validated for worry-free, fully supported use in Dell servers.

OCP 3.0 support

Table 17. OCP 3.0 feature list

Feature	OCP 3.0
Form factor	SFF
PCIe Gen	Gen4
Max PCIe width	x8
Max no.of ports	4
Port type	BT/SFP/SFP+/SFP28/SFP56
Max port speed	25 GbE
NC-SI	Yes
SNAPI	Yes
WoL	Yes
Power consumption	35 W

Supported OCP cards

Table 18. Supported OCP cards

Form factor	Vendor	Port type	Port speed	Port count
OCP 3.0	Broadcom	BT	10 GbE	4
	Intel	SFP28	25 GbE	2
	Mellanox	SFP28	25 GbE	2
	Broadcom	SFP28	25 GbE	2

OCP NIC 3.0 vs. rack Network Daughter Card comparisons

Table 19. OCP 3.0, 2.0, and rNDC NIC comparison

Form Factor	Dell rNDC	OCP 2.0 (LOM Mezz)	OCP 3.0	Notes
PCIe Gen	Gen 3	Gen 3	Gen 4	Supported OCP3 are SFF (small form factor)
Max PCIe Lanes	x8	Up to x16	Up to x16	See server slot priority matrix
Shared LOM	Yes	Yes	Yes	This is iDRAC port redirect
Aux Power	Yes	Yes	Yes	Used for Shared LOM

OCP form factors

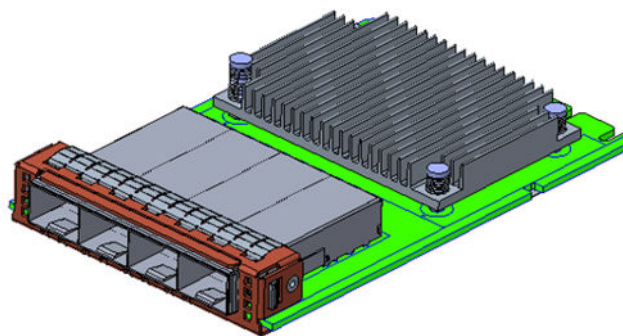

Figure 7. OCP 3.0 Small Card Form Factor (LS)

The process of installing the OCP card in XE9640 system:

1. Open the blue latch on the system board.
2. Slide the OCP card into the slot in the system.
3. Push until the OCP card is fully connected to the connector on the system board.
4. Close the latch to lock the OCP card to the system.

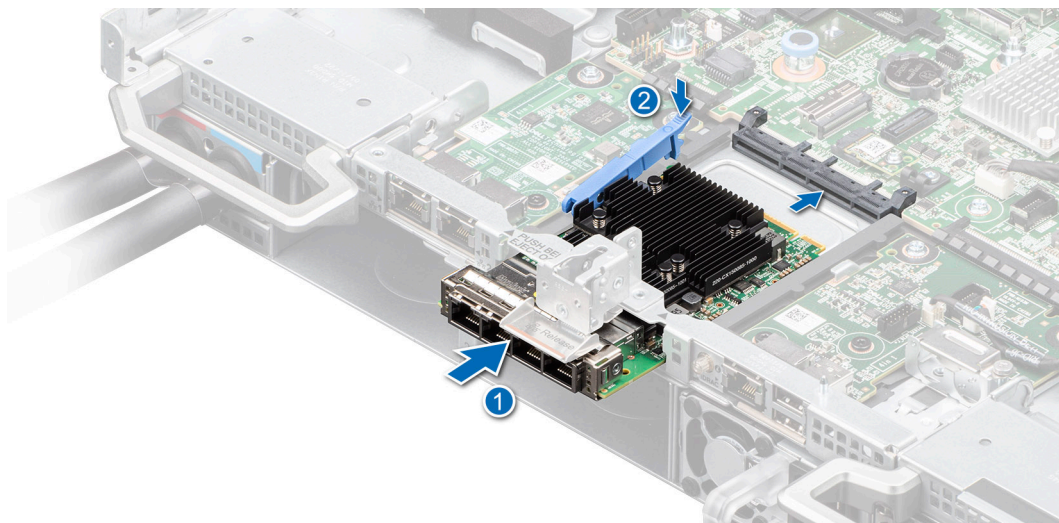

Figure 8. Installing the OCP Card in XE9640

The process of removing the OCP card in XE9640 system:

1. Open the blue latch to unlock the OCP card.
2. Push the OCP card towards the rear end of the system to disconnect from the connector on the system board.
3. Slide the OCP card out of the slot on the system

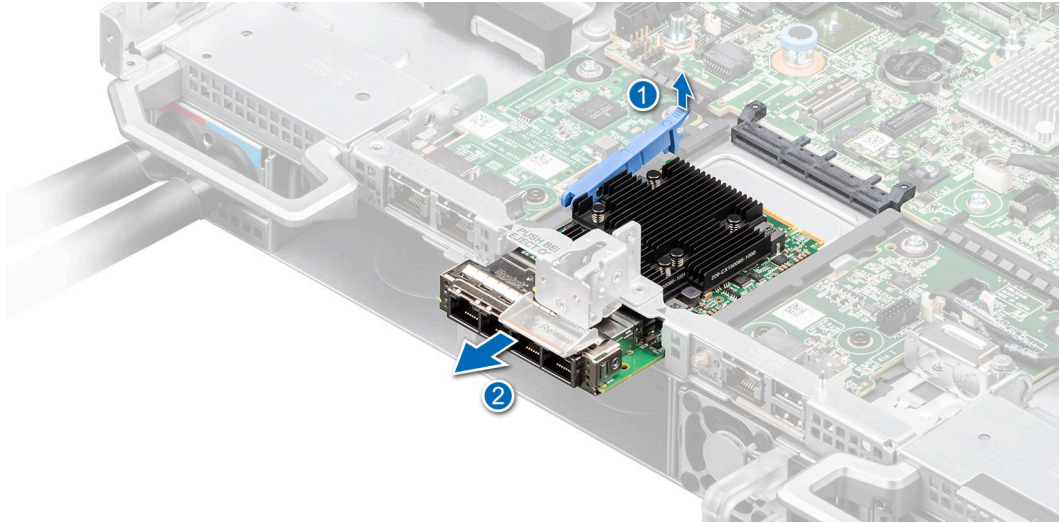

Figure 9. Removing the OCP Card in XE9640

PCIe subsystem

Topics:

- PCIe slot mechanical compatibility matrix
- Slot priority matrix

PCIe slot mechanical compatibility matrix

Table 20. PCIe Riser Configurations

Config No.	Riser configuration	No. of Processors	PERC type supported	Rear storage possible
2	R1A+R4A	2	NA	No
3	R1B+R4B	2	NA	No

Table 21. Configuration 2 : Expansion card slots for XE9640 with Intel GPUs

Expansion card riser	PCIe slot	Processor Connection	PCIe slot height	PCIe slot length	PCIe slot width
Riser 1A (R1A)	1	Processor 1	Full height	Half length	x16
	2	Processor 1	Low Profile	Half length	x16
Riser 4A (R4A)	3	Processor 2	Low Profile	Half length	x16
	4	Processor 2	Full height	Half length	x16

Table 22. Configuration 3 : Expansion card slots for XE9640 with NVIDIA GPUs

Expansion card riser	PCIe slot	Processor Connection	PCIe slot height	PCIe slot length	PCIe slot width
Riser 1B (R1B)	1	Processor 1	Full height	Half length	x16
	2	Processor 1	Low Profile	Half length	x16
Riser 4B (R4B)	3	Processor 2	Low Profile	Half length	x16
	4	Processor 2	Full height	Half length	x16

Slot priority matrix

For add-in cards that can be mapped to the XE9640 and guidelines for installing expansion cards, see the XE9640 slot priority matrix file on Sales Portal.

Link:<https://www.delltechnologies.com/resources/en-us/auth/products/servers/category.htm>

Power, thermal, and acoustics

PowerEdge servers have an extensive collection of sensors that automatically track thermal activity, which helps regulate temperature thereby reducing server noise and power consumption. The table below lists the tools and technologies Dell offers to lower power consumption and increase energy efficiency.

Topics:

- [Power](#)
- [Thermal](#)
- [Acoustics](#)

Power

Table 23. Power tools and technologies

Feature	Description
Power Supply Units(PSU) portfolio	Dell's PSU portfolio includes intelligent features such as dynamically optimizing efficiency while maintaining availability and redundancy. Find additional information in the Power supply units section.
PSU redundancy options	<ul style="list-style-type: none"> • 2+0 Non redundant, full power with 2x PSUs • 2+1 - N+1 redundancy • 2+2 - N+N redundancy
Tools for right sizing	Enterprise Infrastructure Planning Tool (EIPT) is a tool that can help you determine the most efficient configuration possible. With Dell's EIPT, you can calculate the power consumption of your hardware, power infrastructure, and storage at a given workload. Learn more at www.dell.com/calc .
Industry Compliance	Dell's servers are compliant with all relevant industry certifications and guide lines, including 80 PLUS.
Power monitoring accuracy	PSU power monitoring improvements include: <ul style="list-style-type: none"> • Dell's power monitoring accuracy is currently 1%, whereas the industry standard is 5% • More accurate reporting of power • Better performance under a power cap
Power capping	Use Dell's systems management to set the power cap limit for your systems to limit the output of a PSU and reduce system power consumption. Dell is the first hardware vendor to leverage Intel Node Manager for circuit-breaker fast capping.
Systems Management	iDRAC Enterprise and Datacenter provides server-level management that monitors, reports and controls power consumption at the processor, memory and system level. Dell OpenManage Power Center delivers group power management at the rack, row, and data center level for servers, power distribution units, and uninterruptible power supplies.
Active power management	Intel Node Manager is an embedded technology that provides individual server-level power reporting and power limiting functionality. Dell offers a complete power management solution comprised of Intel Node Manager accessed through Dell iDRAC9 Datacenter and OpenManage Power Center that allows policy-based management of power and thermal at the individual server, rack, and data center level. Thermal control off a speed optimizes the thermal settings for your environment to reduce fan consumption and lower system power consumption.

Table 23. Power tools and technologies (continued)

Feature	Description
	Idle power enables Dell servers to run as efficiently when idle as when at full workload.
Fresh Air cooling	Refer to ASHRAE A3/A4 Thermal Restriction.
Rack infrastructure	<p>Dell offers some of the industry's highest-efficiency power infrastructure solutions, including:</p> <ul style="list-style-type: none"> • Power distribution units (PDUs) • Uninterruptible power supplies (UPSs) • Energy Smart containment rack enclosures <p>Find additional information at: https://www.delltechnologies.com/en-us/servers/power-and-cooling.htm.</p>

Power Supply Units

Energy Smart power supplies have intelligent features, such as the ability to dynamically optimize efficiency while maintaining availability and redundancy. Also featured are enhanced power-consumption reduction technologies, such as high-efficiency power conversion and advanced thermal-management techniques, and embedded power-management features, including high-accuracy power monitoring. The table below shows the power supply unit options that are available for the XE9640.

Table 24. PSU specifications for the PowerEdge XE9640 system

PSU	Class	Heat dissipation (maximum)	Frequency	Voltage	Current
2800 W Mixed Mode	Titanium	10500 BTU/hr	50/60 Hz	200 - 240 V AC	15.6 A
	N/A	10500 BTU/hr	N/A	240 V DC	13.6 A

Thermal

PowerEdge servers have an extensive collection of sensors that automatically track thermal activity, which helps regulate temperature thereby reducing server noise and power consumption.

Thermal design

Thermal management of the platform helps deliver high performance with the right amount of cooling to components, while maintaining the lowest fan speeds possible. This is done across a wide range of ambient temperatures from 10°C to 35°C (50°F to 95°F) and to extended ambient temperature ranges.

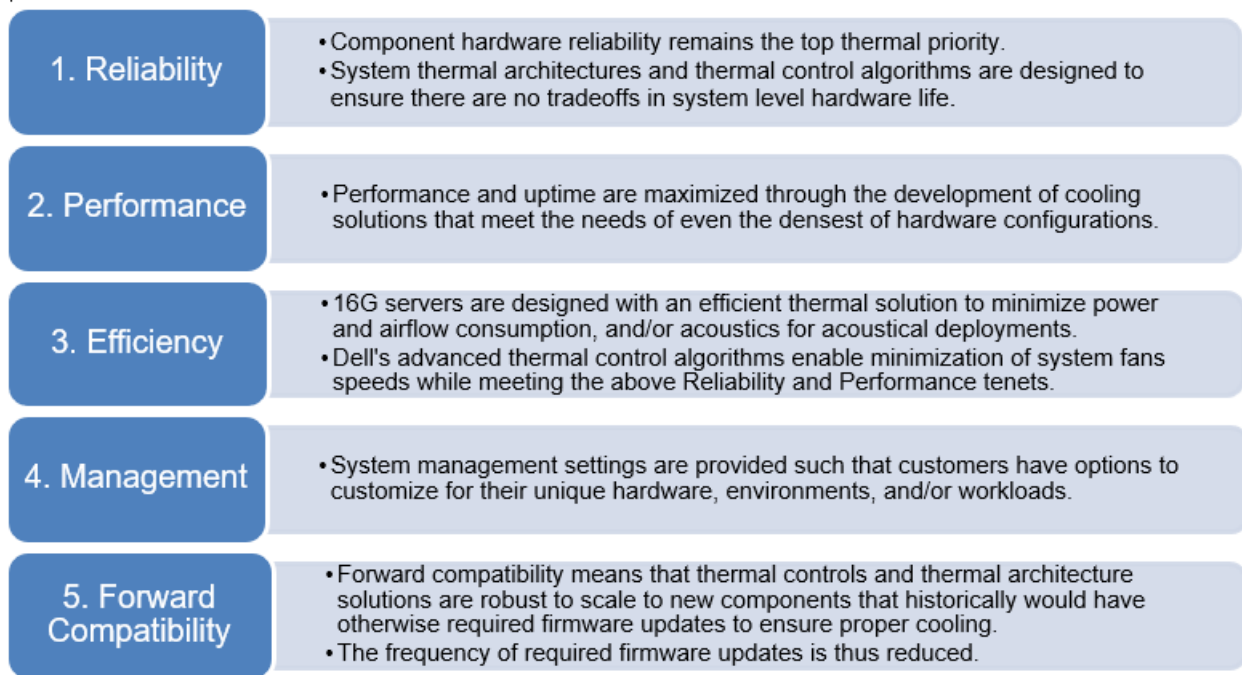

Figure 10. Thermal design characteristics

The thermal design of the PowerEdge XE9640 reflects the following:

- Optimized thermal design: The system layout is architected for optimum thermal design.
- System component placement and layout are designed to provide maximum airflow coverage to critical components with minimum expense of fan power.
- Comprehensive thermal management: The thermal control system regulates the fan speed based on several different responses from all system-component temperature sensors, as well as inventory for system configurations. Temperature monitoring includes components such as processors, DIMMs, chipset, the inlet air ambient, hard disk drives, OCP and GPU.
- Open and closed loop thermal fan speed control: Open loop thermal control uses system configuration to determine fan speed based on inlet air ambient temperature. Closed loop thermal control method uses feedback temperatures to dynamically determine proper fan speeds.
- User-configurable settings: With the understanding and realization that every customer has unique set of circumstances or expectations from the system, in this generation of servers, we have introduced limited user- configurable settings residing in the iDRAC BIOS setup screen. For more information, see the Dell PowerEdge XE9640 Installation and Service Manual at www.dell.com/poweredgemanuals and “Advanced Thermal Control: Optimizing across Environments and Power Goals” on Dell.com.
- Cooling redundancy: The PowerEdge XE9640 The XE9640 supports the following power supply configurations at RTS. Note that during normal operation, power load will be shared evenly across all available PSUs.
 - 2+0 - Non redundant, full power with 2x PSUs
 - 2+1 - N+1 redundancy
 - 2+2 - N+N redundancy
- Environmental Specifications: The optimized thermal management makes the PowerEdge XE9640 reliable under a wide range of operating environments.

Thermal restriction matrix

	Configuration		2 x NVMe	4 x NVMe	8 x E3 (Post-RTS)	No Backplane
	GPUs		Intel Max 1550 GPU	Nvidia H100 GPU chassis	Nvidia H100 GPU	Nvidia H100 GPU
Processors	8468	350 W	35° C	35° C		
	8480+	350 W	NA	35° C		

	Configuration		2 x NVMe	4 x NVMe	8 x E3 (Post-RTS)	No Backplane
	8470Q	350 W	NA	35° C		
	8470	350 W	NA	35° C		
	8460+	300 W	NA	35° C		
	8452Y	300 W	NA	35° C		
Memory	64 GB RDIMM 4800 MT/s	1 DPC/ 2 DPC	35° C	35° C		
BOSS			35° C	35° C		
PCIe			35° C	35° C		
OCP			35° C	35° C		

Acoustics

Acoustical design

Dell PowerEdge delivers sound quality and smooth transient response in addition to sound power levels and sound pressure levels oriented to deployment environments.

Sound quality describes how disturbing or pleasing a person finds a sound, as a function of a variety of psycho-acoustical metrics and thresholds. Tone prominence is one such metric.

Transient response refers to how sound changes with time.

Sound power level, sound pressure level and loudness refer to amplitude of sound.

A reference for comparison to sound pressure levels and loudness for familiar noise sources is given in the table below.

Table 25. Acoustical Reference Points and Output Comparisons

Value measured at your ears		Equivalent familiar noise experience
LpA, dBA, re 20µPa	Loudness, sones	
90	80	Loud concert
75	40	Data center, vacuum cleaner, voice must be elevated to be heard
60	10	Conversation levels
45	4	Whispering, open office layout, normal living room
35	2	Quiet office
30	1	Quiet library
20	0	Recording studio

For more information about PowerEdge acoustical design and metrics, see [Understanding Acoustical Data and Causes of Sound in Dell Enterprise Products](#).

PowerEdge XE9640 acoustics

Dell PowerEdge XE9640 is a rack data center server with direct liquid cooling solution on key components (CPU, GPU, etc). Acoustical performance is provided in terms of two configurations: Each configuration has been tested according to Dell acoustical standards for blades data center servers. Configuration details are provided in the below table:

Table 26. Acoustical configurations of XE9640

Configuration	XE9640 with Intel GPUs	XE9640 with NVIDIA GPUs
CPU Type	Intel	Intel
CPU TDP	350W	350W
CPU Quantity	2 CPU	2 CPU
RDIMM Memory	64 GB	64 GB
Memory Quantity	16	32
Backplane Type	U2	U2
SSD Type	NVME	NVME
SSD Quantity	2	4
PSU Type	2800W	2800W
PSU Quantity	4	4
Mezz 1	N/A	N/A
BOSS Card	BOSS-N1	BOSS-N1
PERC	N/A	N/A
GPU	Intel Max 1550 GPU 600W	NV H100 700W (80G)
Adapter Card-1	NDR200(FH)	NDR400(FH)
Adapter Card-2	NDR200(LP)	NDR400(LP)
Adapter Card-3	NDR200(LP)	NDR400(LP)
Adapter Card-4	NDR200(FH)	NDR400(FH)

Acoustical performance data associated with each configuration of XE9640 is provided in the below table:

Table 27. Acoustical performance of XE9640

Configuration		XE9640 with Intel GPUs	XE9640 with NVIDIA GPUs
Acoustical Performance: Idle/ Operating @ 25 °C Ambient			
L _{wA,m} (B)	Idle	5.8	6.2
	Operating	6.9	6.8
K _v (B)	Idle	0.4	0.4
	Operating	0.4	0.4
L _{pA,m} (dB)	Idle	43	45
	Operating	52	53
Prominent tones		No prominent tones in Idle and Operating	
Acoustical Performance: Idle @ 28 °C Ambient			
L _{wA,m} (B)		6.1	6.5
K _v (B)		0.4	0.4
L _{pA,m} (dB)		46	50
Acoustical Performance: Max. Loading @ 35 °C Ambient			
L _{wA,m} (B)		7.8	8.2
K _v (B)		0.4	0.4

Table 27. Acoustical performance of XE9640 (continued)

Configuration	XE9640 with Intel GPUs	XE9640 with NVIDIA GPUs
L _{pA,m} (dB)	60	66

- L_{wA,m}: The declared mean A-weighted sound power level (L_{wA}) is calculated per section 5.2 of ISO 9296 with data collected using the methods described in ISO 7779. Data presented here may not be fully compliant with ISO 7779.
- L_{pA,m}: The declared mean A-weighted emission sound pressure level is at the bystander position per section 5.3 of ISO 9296 and measured using methods described in ISO 7779. The system is placed in a 24U rack enclosure, 25cm above a reflective floor. Engineering data presented here may not be fully compliant with ISO 7779 declaration requirements.
- **Prominent discrete tones:** Criteria of Annex D of ECMA-74 & Prominence Ratio method of ECMA-418 are followed to determine if discrete tones are prominent and to report them, if so.
- **Idle mode:** The steady-state condition in which the server is energized but not operating any intended function.
- **Operating mode:** Operating mode is represented by the maximum of the steady state acoustical output at 50% of CPU TDP or active storage drives for the respective sections of Annex C of ECMA-74.

Category 1: Table-top in Office Environment

When Dell determines that a specific Enterprise product is to be used on a Table-top in Office Environment, e.g., on a desk around a seated user’s head height, then the acoustical specification of the below table applies. Small, light-weight towers are examples of these types of products.

Table 28. Dell Enterprise Category 1, “Table-top in Office Environment” acoustical specification category

Measurement Position re AC0158	Metric, re AC0159	Test Modes, re AC0159 (note must be in steady state, see AC0159, except where noted below)			
		Standby in 23±2° C Ambient	Idle in 23±2° C Ambient	Operating in 23±2° C Ambient – if not otherwise specified in the program’s configuration document, then processor and hard drive operating modes are required	Simulate (i.e., set fan speeds representative) for Idle at 28 & 35° C Ambient, and for 100% loading and maximum configuration, at 35° C Ambient
Sound Power	L _{WA,m} , B	≤ 4.2	≤ 4.7	≤ 5.0	Report
Sound Quality (both positions must meet limits): Front Binaural HEAD and Rear Microphone	Tones, Hz, dB	No prominent tones per criteria D.10.6 and D.10.8 of ECMA-74			Report tones
	Tonality, tu	≤ 0.35	≤ 0.35	≤ 0.35	Report
	Dell Modulation, %	≤ 35	≤ 35	≤ 35	Report
	Loudness, sones	Report	Report	Report	Report
	L _{pA} -single point, dBA	Report	Report	Report	Report
Front Binaural HEAD	Transients	<ul style="list-style-type: none"> • Oscillation (see AC0159), if observed, during 20-minute steady-state observation, must adhere to the following two criteria: <ul style="list-style-type: none"> ○ Max. {ΔL_{pA}} < 3.0 dB ○ Event count < 3 for “1.5 dB < ΔL_{pA} < 3.0 dB” ○ Acoustical Jump (see AC0159), during air mover speed transition from Idle to Operating Mode must be ≤ 15dB. • Startup behavior <ul style="list-style-type: none"> ○ Report Startup behavior re. AC0159 			N/A

Table 28. Dell Enterprise Category 1, “Table-top in Office Environment” acoustical specification category (continued)

		<ul style="list-style-type: none"> ○ Startup must proceed smoothly, i.e., no sudden or large jumps, and fan speed during startup must not exceed 50% of its maximum ● Transient inputs: Report time-history sound pressure levels re AC0159 “Train of Step Functions on Processor” 			
Any	Other	<p>No rattles, squeaks, or unexpected noises</p> <p>Sound should be “even” around the EUT (one side should not be dramatically louder than another)</p> <p>Unless otherwise specified, the “default” thermal-related settings shall be selected for BIOS and iDRAC.</p> <p>Specific operating conditions will be defined in “Configurations & Configuration Dependencies” for each platform.</p>			
Sound Pressure	LpA-reported, dBA, re AC0158 and program configuration document	Report for all mics	Report for all mics	Report for all mics	Report for all mics

Category 2: Floor-standing in Office Environment

When Dell determines that a specific Enterprise product is to be used primarily when it is sitting on the floor, i.e., next to a user’s feet, then the acoustical specification of the below table applies. Noise from the product should not annoy or otherwise interfere with the user’s thoughts or speech, e.g., on the telephone.

Table 29. Dell Enterprise Category 2, “Floor-standing in Office Environment” acoustical specification category

Measurement Position re AC0158	Metric, re AC0159	Test Modes, re AC0159 (note must be in steady state, see AC0159, except where noted below)			
		Standby in 23±2° C Ambient	Idle in 23±2° C Ambient	Operating in 23±2° C Ambient – if not otherwise specified in the program’s configuration document, then processor and hard drive operating modes are required	Simulate (i.e., set fan speeds representative) for Idle at 28 & 35° C Ambient, and for 100% loading and maximum configuration, at 35° C Ambient
Sound Power	LWA,m, B	≤ 4.9	≤ 5.1	≤ 5.4	Report
Sound Quality (both positions must meet limits): Front Binaural HEAD and Rear Microphone	Tones, Hz, dB	No prominent tones per criteria D.10.6 and D.10.8 of ECMA-74			Report tones
	Tonality, tu	≤ 0.35	≤ 0.35	≤ 0.35	Report
	Dell Modulation, %	≤ 35	≤ 35	≤ 35	Report
	Loudness, sones	Report	Report	Report	Report
	LpA-single point, dBA	Report	Report	Report	Report

Table 29. Dell Enterprise Category 2, “Floor-standing in Office Environment” acoustical specification category (continued)

Front Binaural HEAD	Transients	<ul style="list-style-type: none"> Oscillation (see AC0159), if observed, during 20-minute steady-state observation, must adhere to the following two criteria: <ul style="list-style-type: none"> Max. {ΔLpA} < 3.0 dB Event count < 3 for “1.5 dB < ΔLpA < 3.0 dB” Acoustical Jump (see AC0159), during air mover speed transition from Idle to Operating Mode must be ≤ 15dB. Startup behavior <ul style="list-style-type: none"> Report Startup behavior re. AC0159 Startup must proceed smoothly, i.e., no sudden or large jumps, and fan speed during startup must not exceed 50% of its maximum <p>∞ Transient inputs: Report time-history sound pressure levels re AC0159 “Train of Step Functions on Processor”</p>				N/A
Any	Other	<p>No rattles, squeaks, or unexpected noises</p> <p>Sound should be “even” around the EUT (one side should not be dramatically louder than another)</p> <p>Unless otherwise specified, the “default” thermal-related settings shall be selected for BIOS and iDRAC.</p> <p>Specific operating conditions will be defined in “Configurations & Configuration Dependencies” for each platform.</p>				
Sound Pressure	LpA-reported, dBA, re AC0158 and program configuration document	Report for all mics	Report for all mics	Report for all mics	Report for all mics	

Category 3: General Use Space

When Dell determines that a specific Enterprise product is to be predominantly used in a general use space, then the acoustical specification of the below table applies. These products could be found in laboratories, schools, restaurants, open office space layouts, small ventilated closets, etc., though not in close proximity to any particular person nor in quantities greater than a few in any location. People within proximity of a few of these products should not experience any impact to speech intelligibility or annoyance from the noise of the product. A rack product sitting on a table in a common area is an example.

Table 30. Dell Enterprise Category 3, “General Use” acoustical specification category

Measurement Position re AC0158	Metric, re AC0159	Test Modes, re AC0159 (note must be in steady state, see AC0159, except where noted below)			
		Standby in 23±2° C Ambient	Idle in 23±2° C Ambient	Operating in 23±2° C Ambient – if not otherwise specified in the program’s configuration document, then processor and hard drive operating modes are required	Simulate (i.e., set fan speeds representative) for Idle at 28 & 35° C Ambient, and for 100% loading and maximum configuration, at 35° C Ambient
Sound Power	LWA,m, B	≤ 5.2	≤ 5.5	≤ 5.8	Report

Table 30. Dell Enterprise Category 3, “General Use” acoustical specification category (continued)

Sound Quality (both positions must meet limits): Front Binaural HEAD and Rear Microphone	Tones, Hz, dB	No prominent tones per criteria D.10.6 and D.10.8 of ECMA-74			Report tones
	Tonality, tu	≤ 0.35	≤ 0.35	≤ 0.35	Report
	Dell Modulation, %	≤ 35	≤ 35	≤ 35	Report
	Loudness, sones	Report	Report	Report	Report
	LpA-single point, dBA	Report	Report	Report	Report
Front Binaural HEAD	Transients	<ul style="list-style-type: none"> • Oscillation (see AC0159), if observed, during 20-minute steady-state observation, must adhere to the following two criteria: <ul style="list-style-type: none"> ○ Max. {ΔLpA} < 3.0 dB ○ Event count < 3 for “1.5 dB < ΔLpA < 3.0 dB” ○ Acoustical Jump (see AC0159), during air mover speed transition from Idle to Operating Mode must be ≤ 15dB. • Startup behavior <ul style="list-style-type: none"> ○ Report Startup behavior re. AC0159 ○ Startup must proceed smoothly, i.e., no sudden or large jumps, and fan speed during startup must not exceed 50% of its maximum <p>∞ Transient inputs: Report time-history sound pressure levels re AC0159 “Train of Step Functions on Processor”</p>			N/A
Any	Other	<p>No rattles, squeaks, or unexpected noises</p> <p>Sound should be “even” around the EUT (one side should not be dramatically louder than another)</p> <p>Unless otherwise specified, the “default” thermal-related settings shall be selected for BIOS and iDRAC.</p> <p>Specific operating conditions will be defined in “Configurations & Configuration Dependencies” for each platform.</p>			
Sound Pressure	LpA-reported, dBA, re AC0158 and program configuration document	Report for all mics	Report for all mics	Report for all mics	Report for all mics

Category 4: Attended Data Center

When Dell determines that a specific Enterprise product is to be predominantly used in an attended data center, then the acoustical specification of the below table applies. The phrase “attended data center” is used to mean a space in which many (from tens to 1000s) of Enterprise products are deployed in proximity (i.e., in the same room) to personnel whose speech (perhaps with raised voices) is expected to be intelligible over the data center noise. Hearing protection or hearing monitoring programs are not expected in these areas. Examples in this category include monolithic rack products. When Dell determines that a specific Enterprise product is to be predominantly used in a general use space, then the acoustical specification of Table 37 applies. These products could be found in laboratories, schools, restaurants, open office space layouts, small ventilated closets, etc., though not in close proximity to any particular person nor in quantities greater than a few in any location. People within proximity of a few of these products should not experience any impact to speech intelligibility or annoyance from the noise of the product. A rack product sitting on a table in a common area is an example.

Table 31. Dell Enterprise Category 4, “Attended Data Center” acoustical specification category

Measurement Position re AC0158	Metric, re AC0159	Test Modes, re AC0159 (note must be in steady state, see AC0159, except where noted below)				Simulate (i.e., set fan speeds representative) for 100% loading and maximum configuration, at 35° C Ambient
		Standby in 23±2° C Ambient	Idle in 23±2° C Ambient	Operating in 23±2° C Ambient – if not otherwise specified in the program’s configuration document, then processor and hard drive operating modes are required	Simulate (i.e., set fan speeds representative) for Idle at 28 & 35° C Ambient	
Sound Power	LWA,m, B	Report	≤ 6.9	≤ 7.1	Report	Report
Front Binaural HEAD	Tones, Hz, dB	Report	< 15 dB	< 15 dB	Report	Report
	Tonality, tu	Report	Report	Report	Report	Report
	Dell Modulation, %	Report	Report	Report	Report	Report
	Loudness, sones	Report	Report	Report	Report	Report
	LpA-single point, dBA	Report	Report	Report	Report	Report
	Transients	<ul style="list-style-type: none"> ● Oscillation (see AC0159), if observed, during 20-minute steady-state observation, must adhere to the following two criteria: <ul style="list-style-type: none"> ○ Max. {ΔLpA} < 3.0 dB ○ Event count < 3 for “1.5 dB < ΔLpA < 3.0 dB” ○ Acoustical Jump (see AC0159), during air mover speed transition from Idle to Operating Mode must be ≤ 15dB. ○ Startup behavior <ul style="list-style-type: none"> ■ Report Startup behavior re. AC0159 ■ Startup must proceed smoothly, i.e., no sudden or large jumps, and fan speed during startup must not exceed 50% of its maximum <p>∞ Transient inputs: Report time-history sound pressure levels re AC0159 “Train of Step Functions on Processor”</p>				N/A
Any	Other	<p>No rattles, squeaks, or unexpected noises</p> <p>Sound should be “even” around the EUT (one side should not be dramatically louder than another)</p> <p>Unless otherwise specified, the “default” thermal-related settings shall be selected for BIOS and iDRAC.</p> <p>Specific operating conditions will be defined in “Configurations & Configuration Dependencies” for each platform.</p>				
Sound Pressure	LpA-reported, dBA	Report for all mics	Report for all mics	Report for all mics	Report for all mics	Report for all mics

Unattended Data Center

When Dell determines that a specific Enterprise product is to be predominantly used in an unattended data center (and not blades or blade enclosures; these have their own category), then the acoustical specification of the below table applies. The phrase “unattended data center” is used to mean a space in which many (from tens to 1000s) of Enterprise products are deployed together, its own heating and cooling systems condition the space, and operators or servicers of equipment enter generally only to deploy, service, or decommission equipment. Hearing protection or hearing monitoring programs may be expected (per government or company guidelines) in these areas. Examples in this category include monolithic rack products.

Table 32. Dell Enterprise Category 5, “Unattended Data Center” acoustical specification category

Measurement Position re AC0158	Metric, re AC0159	Test Modes, re AC0159 (note must be in steady state, see AC0159, except where noted below)			
		Standby in 23±2° C Ambient	Idle in 23±2° C Ambient	Operating in 23±2° C Ambient – if not otherwise specified in the program’s configuration document, then processor and hard drive operating modes are required	Simulate (i.e., set fan speeds representative) for Idle at 28 & 35° C Ambient, and for 100% loading and maximum configuration, at 35° C Ambient
Sound Power	LWA,m, B	Report	≤ 7.5	≤ 7.7	Report
Sound Quality (both positions must meet limits): Front Binaural HEAD and Rear Microphone	Tones, Hz, dB	Report	< 15 dB	< 15 dB	Report
	Tonality, tu	Report	Report	Report	Report
	Dell Modulation, %	Report	Report	Report	Report
	Loudness, sones	Report	Report	Report	Report
	LpA-single point, dBA	Report	Report	Report	Report
Front Binaural HEAD	Transients	<ul style="list-style-type: none"> ● Oscillation (see AC0159), if observed, during 20-minute steady-state observation, must adhere to the following two criteria: <ul style="list-style-type: none"> ○ Max. {ΔLpA} < 3.0 dB ○ Event count < 3 for “1.5 dB < ΔLpA < 3.0 dB” ○ Acoustical Jump (see AC0159) ΔLpA during fan speed transitions between operating states . ○ Startup behavior <ul style="list-style-type: none"> ■ Report Startup behavior re. AC0159 ■ Startup must proceed smoothly, i.e., no sudden or large jumps, and fan speed during startup must not exceed 50% of its maximum ∞ Transient inputs: Report time-history sound pressure levels re AC0159 “Train of Step Functions on Processor” 			N/A
Any	Other	<p>No rattles, squeaks, or unexpected noises</p> <p>Sound should be “even” around the EUT (one side should not be dramatically louder than another)</p> <p>Unless otherwise specified, the “default” thermal-related settings shall be selected for BIOS and iDRAC.</p>			

Table 32. Dell Enterprise Category 5, “Unattended Data Center” acoustical specification category (continued)

		Specific operating conditions will be defined in “Configurations & Configuration Dependencies” for each platform.			
Sound Pressure	LpA-reported, dBA, re AC0158 and program configuration document	Report for all mics	Report for all mics	Report for all mics	Report for all mics

PowerEdge acoustical dependencies

Some product features impact acoustical server output more than others. The following features are considered strong drivers of acoustical response, thus configurations or operating conditions that include these features may increase air mover speed and acoustical output of the server:

- Ambient temperature: Dell evaluates the acoustical performance of servers in a 23±2°C environment. Ambient temperatures in excess of 25°C will have higher acoustical output and may experience larger fluctuations between state changes.
- Processor thermal design power (TDP): Higher wattage processors may require more airflow to cool under load and thus increase the potential acoustical output of the system.
- Storage type: NVME SSD consumes more power than SAS/SATA drives, and will pre-heat down-stream components (e.g., Processor, DIMM), and therefore demands more airflow to achieve system cooling targets.
- **System thermal profile** selection in BIOS or iDRAC GUI:
 - **Default Thermal Profile**, generally provides a lower air mover speed thus lower acoustical output than those of other thermal profiles.
 - Maximum Performance (Performance Optimized) will result in higher acoustical output
- PCIe cards: When 25Gb NIC card or GPU card ≥ 75W is installed, the acoustical outputs will be higher in both idle and operating conditions.
- BOSS module: If any BOSS module is installed and Maximum Performance (Performance Optimized) is selected, fan speed and acoustical noise may significantly increase at IDLE condition.

Rack, rails, and cable management

Key factors in selecting the proper rails include, Identifying:

- Type of rack in which the rails will be installed
- Spacing between the front and rear mounting flanges of the rack
- Type and location of any equipment mounted on the rear of the rack such as power distribution units (PDUs), and the overall depth of the rack

Refer the [Dell Enterprise Systems Rail Sizing and Rack Compatibility Matrix](#) for the following information:

- Specific details about rail types and their functionalities
- Rail adjustability ranges for various rack mounting flange types
- Rail depth with and without cable management accessories
- Rack types supported for various rack mounting flange types

Topics:

- [Rails and cable management information](#)

Rails and cable management information

The rail offerings for the PowerEdge XE9640 consist of one general type: Drop-in/ Stab-in rails (Combo Rail). The cable management offerings consist of an optional strain relief bar (SRB).

See the *Enterprise Systems Rail Sizing and Rack Compatibility Matrix* available at https://i.dell.com/sites/csdocuments/Business_solutions_engineering-Docs_Documents/en/rail-rack-matrix.pdf for information regarding:

- Specific details about rail types.
- Rail adjustability ranges for various rack mounting flange types.
- Rail depth with and without cable management accessories.
- Rack types that are supported for various rack mounting flange types.

Key factors governing proper rail selection include the following:

- Spacing between the front and rear mounting flanges of the rack.
- Type and location of any equipment that is mounted in the back of the rack such as power distribution units (PDUs).
- Overall depth of the rack.

Combo rails features summary

The sliding rails allow the system to be fully extended out of the rack for service. There is only one type of Combo rail available, Stab-in/Drop-in sliding rails. The rails are available with or without the strain relief bar (SRB).

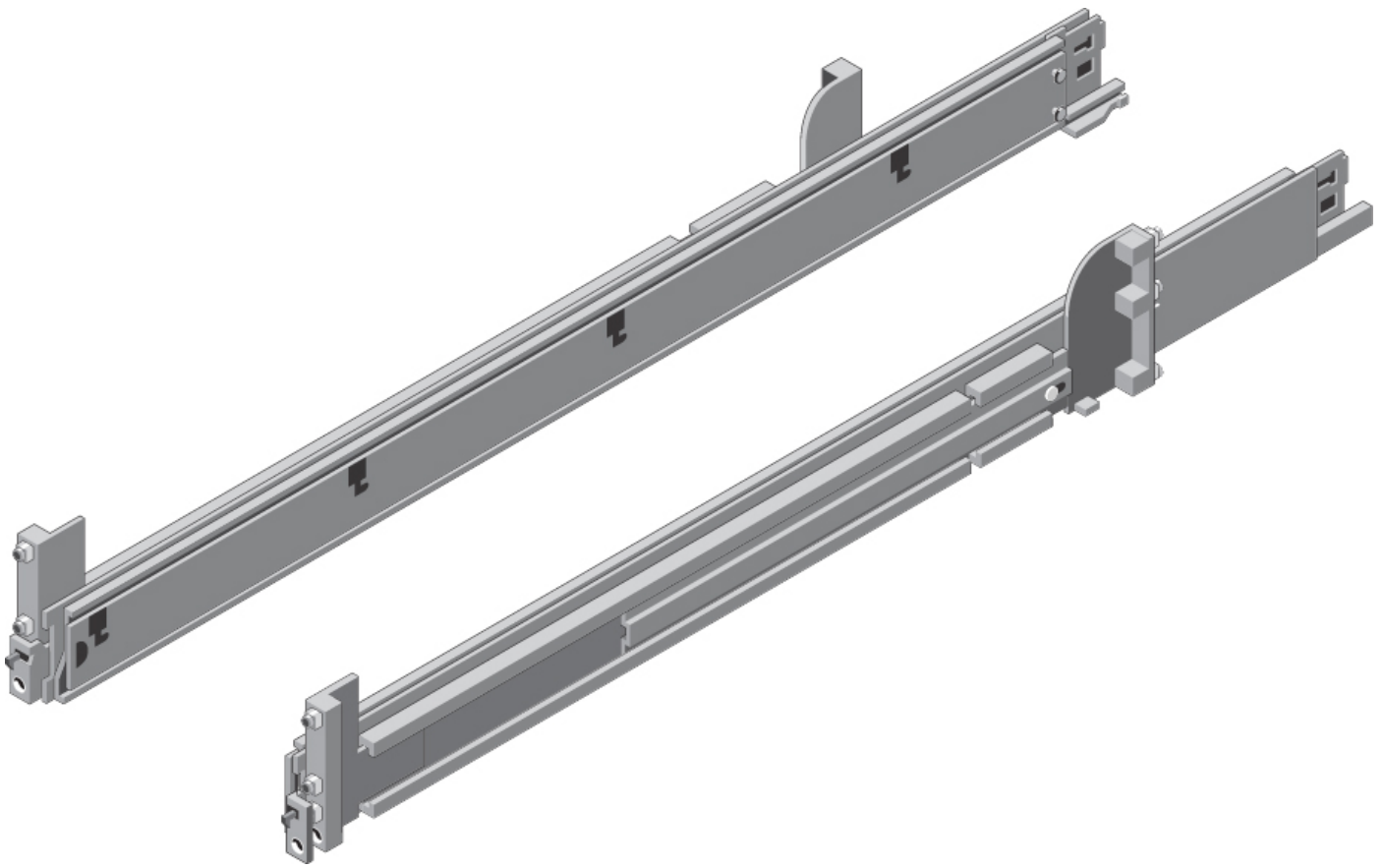

Figure 11. Combo rails

B25 Stab-in/Drop-in sliding rails for 4-post racks

- Supports drop-in or stab-in installation of the chassis to the rails.
- Support for tool-less installation in 19" EIA-310-E compliant square, unthreaded round hole racks including all generations of the Dell racks. Also supports tool-less installation in threaded round hole 4-post racks.
- Support for tool-less installation in Dell Titan or Titan-D racks.
- Support full extension of the system out of the rack to allow serviceability of key internal components.
- Support for optional strain relief bar (SRB).

Scan the QRL code for the documentation and trouble-shooting information regarding the installation procedures for Drop-in/Stab-in rail types.



Figure 12. Quick resource locator for combo rails

Strain Relief Bar (SRB)

The optional strain relief bar (SRB) for the PowerEdge XE9640 organizes and supports cable connections at the rear end of the server to avoid damage from bending.

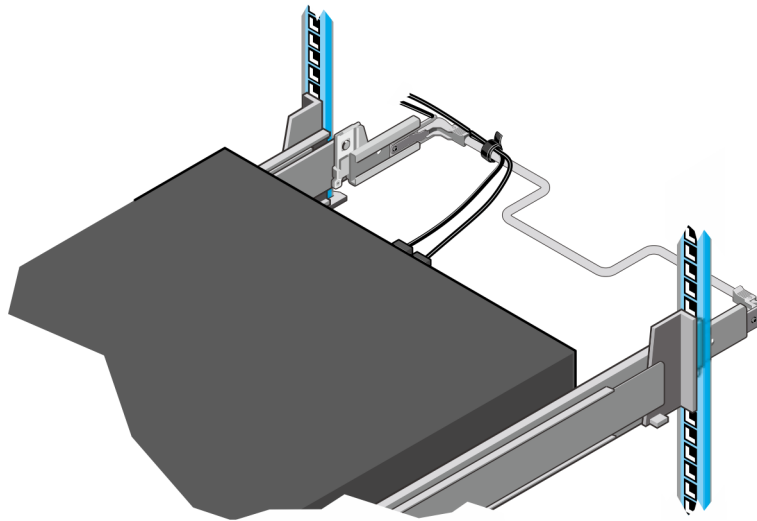

Figure 13. Strain relief bar

- Tool-less attachment to the rails
- Two depth positions to accommodate various cable loads and rack depths
- Supports cable loads and controls stresses on server connectors
- Cables can be segregated into discrete purpose-specific bundles

Rack Installation

Drop-in design means that the system is installed vertically into the rails by inserting the standoffs on the sides of the system into the J-slots in the inner rail members with the rails in the fully extended position. The recommended method of installation is to first insert the rear standoffs on the system into the rear J-slots on the rails to free up a hand and then rotate the system down into the remaining J-slots while using the free hand to hold the rail against the side of the system.

Stab-in design means that the inner (chassis) rail members must first be attached to the sides of the system and then inserted into the outer (cabinet) members installed in the rack.

Installing system into the rack (option A: Drop-In)

1. Pull the inner rails out of the rack until they lock into place.

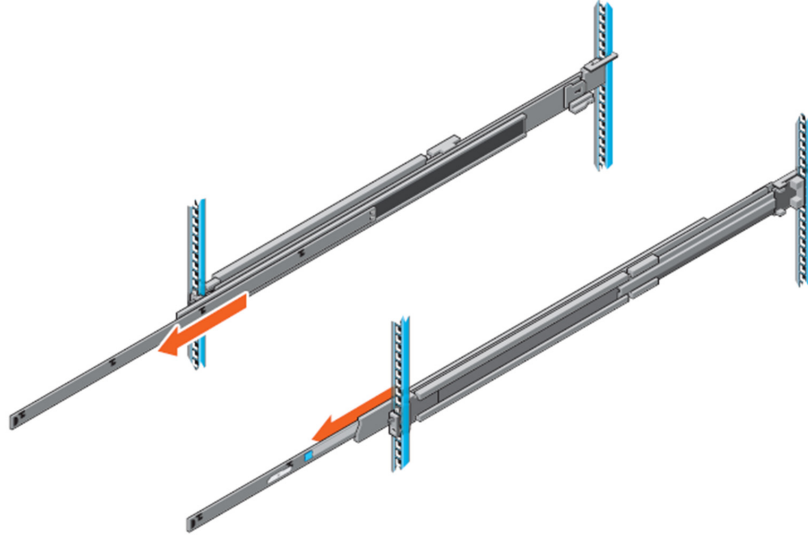

Figure 14. Pull out inner rail

2. Locate the rear rail standoff on each side of the system and lower them into the rear J-slots on the slide assemblies.
3. Rotate the system downward until all the rail standoffs are seated in the J-slots.

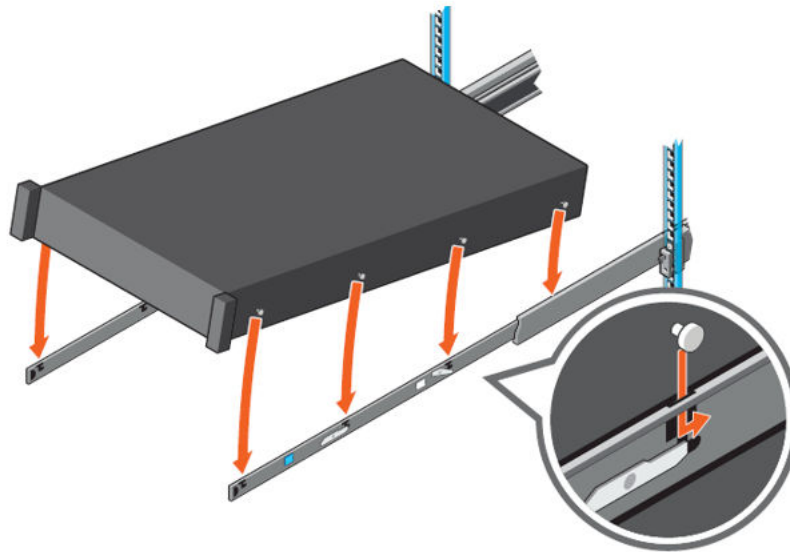

Figure 15. Rail standoffs seated in J-slots

4. Push the system inward until the lock levers click into place.
5. Pull the blue side release lock tabs forward or backward on both rails and slide the system into the rack until the system is in the rack.

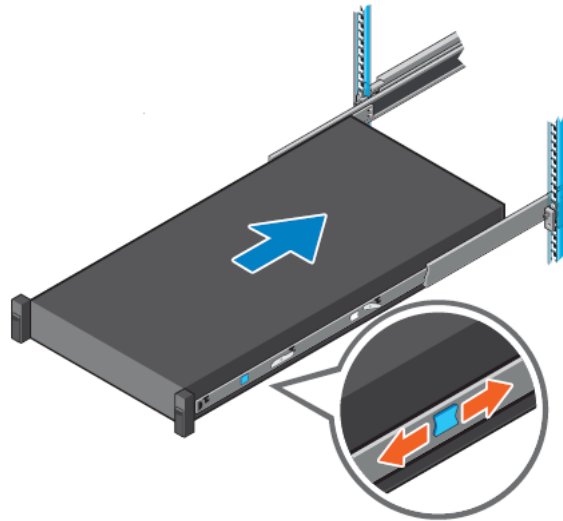

Figure 16. Slide system into the rack

Installing the system into the rack (option B: Stab-In)

1. Pull the intermediate rails out of the rack until they lock into place.
2. Release the inner rail lock by pulling forward on the white tabs and sliding the inner rail out of the intermediate rails.

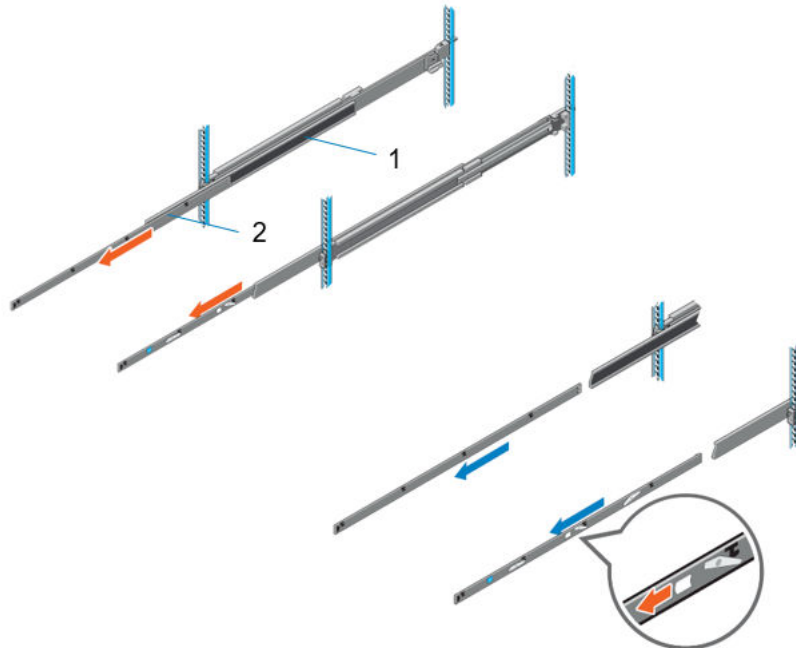

Figure 17. Pull out the intermediate rail

Table 33. Rail component label

Number	Component
1	Intermediate rail
2	Inner rail

3. Attach the inner rails to the sides of the system by aligning the J-slots on the rail with the standoffs on the system and sliding forward on the system until they lock into place.

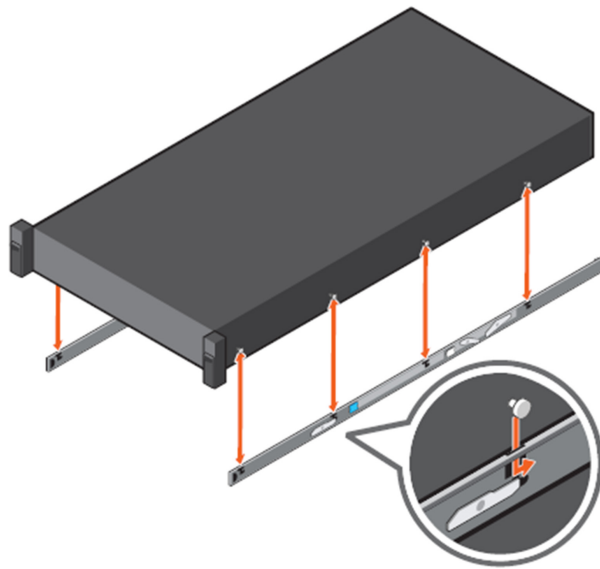

Figure 18. Attach the inner rails to the system

4. With the intermediate rails extended, install the system into the extended rails.

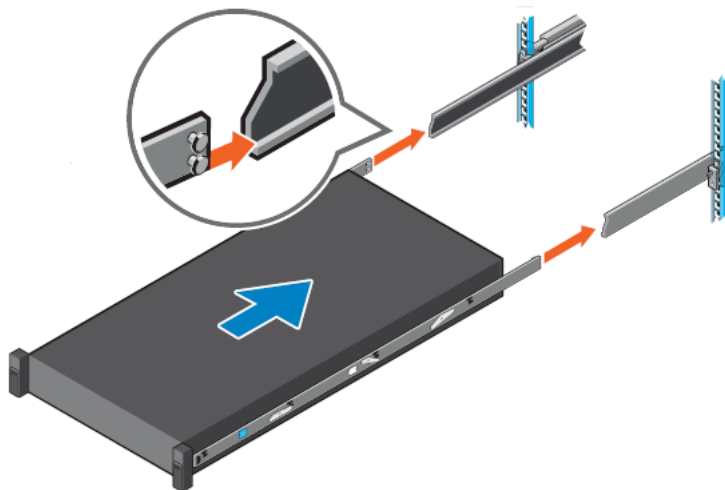

Figure 19. Install system into the extended rails

5. Pull blue slide release lock tabs forward or backward on both rails, and slide the system into the rack.

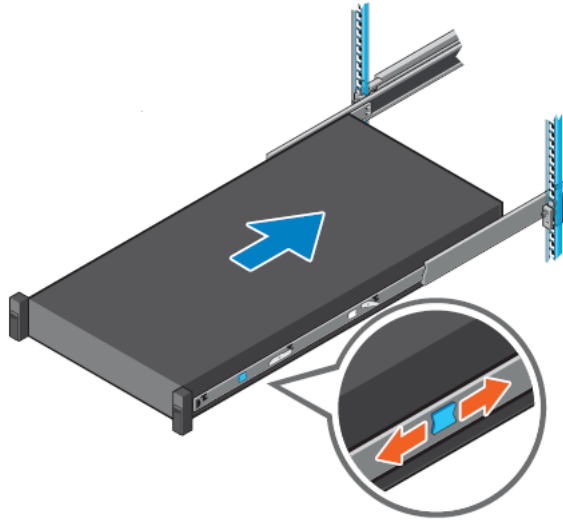

Figure 20. Slide system into the rack

Operating Systems and Virtualization

Topics:

- [Supported operating systems](#)

Supported operating systems

The PowerEdge XE9640 supports the following operating systems:

- Canonical Ubuntu Server LTS
- Red Hat Enterprise Linux

Dell OpenManage Systems Management

Dell delivers management solutions that help IT administrators effectively deploy, update, monitor, and manage IT assets. OpenManage solutions and tools enable you to quickly respond to problems by helping them to manage Dell servers efficiently; in physical, virtual, local, and remote environments; all without the need to install an agent in the operating system.

The OpenManage portfolio includes:

- Innovative embedded management tools - integrated Dell Remote Access Controller (iDRAC)
- Consoles - OpenManage Enterprise
- Extensible with plug-ins - OpenManage Power Manager
- Update tools - Repository Manager

Dell has developed comprehensive systems management solutions that are based on open standards and has integrated with management consoles from partners such as Microsoft and VMware, allowing advanced management of Dell servers. Dell management capabilities extend to offerings from the industry's top systems management vendors and frameworks such as Ansible, Splunk, and ServiceNow. OpenManage tools automate the full span of server life cycle management activities along with powerful RESTful APIs to script or integrate with your choice of frameworks.

For more information about the entire OpenManage portfolio, see:

- The latest [Dell Systems Management Overview Guide](#).

Topics:

- [Integrated Dell Remote Access Controller \(iDRAC\)](#)
- [Systems Management software support matrix](#)

Integrated Dell Remote Access Controller (iDRAC)

iDRAC9 delivers advanced, agent-free, local and remote server administration. Embedded in every PowerEdge server, iDRAC9 provides a secure means to automate a multitude of common management tasks. Because iDRAC is embedded within every PowerEdge server, there is no additional software to install; just plug in power and network cables, and iDRAC is ready to go. Even before installing an operating system (operating system) or hypervisor, IT administrators have a complete set of server management features at their fingertips.

With iDRAC9 in-place across the Dell PowerEdge portfolio, the same IT administration techniques and tools can be applied throughout. This consistent management platform allows easy scaling of PowerEdge servers as an organization's infrastructure grows. Customers can use the iDRAC RESTful API for the latest in scalable administration methods of PowerEdge servers. With this API, iDRAC enables support for the Redfish standard and enhances it with Dell extensions to optimize at-scale management of PowerEdge servers. By having iDRAC at the core, the entire OpenManage portfolio of Systems Management tools allows every customer to tailor an effective, affordable solution for any size environment.

Zero Touch Provisioning (ZTP) is embedded in iDRAC. ZTP - Zero Touch Provisioning is Intelligent Automation Dell's agent-free management puts IT administrators in control. Once a PowerEdge server is connected to power and networking, that system can be monitored and fully managed, whether you're standing in front of the server or remotely over a network. In fact, with no need for software agents, an IT administrator can: · Monitor · Manage · Update · Troubleshoot and remediate Dell servers With features like zero-touch deployment and provisioning, iDRAC Group Manager, and System Lockdown, iDRAC9 is purpose-built to make server administration quick and easy. For those customers whose existing management platform utilizes in-band management, Dell does provide iDRAC Service Module, a lightweight service that can interact with both iDRAC9 and the host operating system to support legacy management platforms.

When ordered with DHCP enabled from the factory, PowerEdge servers can be automatically configured when they are initially powered up and connected to your network. This process uses profile-based configurations that ensure each server is configured per your specifications. This feature requires an iDRAC Enterprise license.

iDRAC9 offers following license tiers:

Table 34. iDRAC9 license tiers

License	Description
iDRAC9 Basic	<ul style="list-style-type: none"> Available only on 100-500 series rack/tower Basic instrumentation with iDRAC web UI For cost conscious customers that see limited value in management
iDRAC9 Express	<ul style="list-style-type: none"> Default on 600+ series rack/tower, modular, and XR series Includes all features of Basic Expanded remote management and server life-cycle features
iDRAC9 Enterprise	<ul style="list-style-type: none"> Available as an upsell on all servers Includes all features of Basic and Express. Includes key features such as virtual console, AD/LDAP support, and more Remote presence features with advanced, Enterprise-class, management capabilities
iDRAC9 Datacenter	<ul style="list-style-type: none"> Available as an upsell on all servers Includes all features of Basic, Express, and Enterprise. Includes key features such as telemetry streaming, Thermal Manage, automated certificate management, and more Extended remote insight into server details, focused on high end server options, granular power, and thermal management

For a full list of iDRAC features by license tier, see [Integrated Dell Remote Access Controller 9 User's Guide](#) at [Dell.com](#).

For more details on iDRAC9 including white papers and videos, see:

- [Support for Integrated Dell Remote Access Controller 9 \(iDRAC9\)](#) on the [Knowledge Base](#) page at [Dell.com](#)

Systems Management software support matrix

Table 35. Systems Management software support matrix

Categories	Features	PE mainstream
Embedded Management and In-band Services	iDRAC9 (Express, Enterprise, and Datacenter licenses)	Supported
	OpenManage Mobile	Not Supported
	OM Server Administrator (OMSA)	Supported
	iDRAC Service Module (iSM)	Supported
	Driver Pack	Not Supported
Change Management	Update Tools (Repository Manager, DSU, Catalogs)	Supported
	Server Update Utility	Not Supported
	Lifecycle Controller Driver Pack	Supported
	Bootable ISO	Supported
Console and Plug-ins	OpenManage Enterprise	Supported
	Power Manager Plug-in	Supported
	Update Manager Plug-in	Supported
	SupportAssist Plug-in	Supported
	CloudIQ	Supported
Integrations and connections	OM Integration with VMware Vcenter/vROps	Supported
	OM Integration with Microsoft System Center (OMIMSC)	Not Supported
	Integrations with Microsoft System Center and Windows Admin Center (WAC)	Not Supported

Table 35. Systems Management software support matrix (continued)

Categories	Features	PE mainstream
	ServiceNow	Supported
	Ansible	Supported
	Third-party Connectors (Nagios, Tivoli, Microfocus)	Supported
Security	Secure Enterprise Key Management	Supported
	Secure Component Verification	Supported
Standard operating system	Red Hat Enterprise Linux, SUSE, Ubuntu	Supported (Tier-1)

Appendix A. Standards compliance

The system conforms to the following industry standards.

Table 36. Industry standard documents

Standard	URL for information and specifications
ACPI Advance Configuration and Power Interface Specification, v6.4	https://uefi.org/specsandtesttools
Ethernet IEEE Std 802.3-2022	https://standards.ieee.org/
MSFT WHQL Microsoft Windows Hardware Quality Labs	microsoft.com/whdc/system/platform/pcdesign/desguide/serverdg.msp
IPMI Intelligent Platform Management Interface, v2.0	intel.com/design/servers/ipmi
DDR5 Memory DDR5 SDRAM Specification	jedec.org/standards-documents/docs/jesd79-4.pdf
PCI Express PCI Express Base Specification, v5.0	pcisig.com/specifications/pciexpress
PMBus Power System Management Protocol Specification, v1.2	http://pmbus.org/Assets/PDFS/Public/PMBus_Specification_Part_1_Rev_1-1_20070205.pdf
SAS Serial Attached SCSI, 3 (SAS-3) (T10/INCITS 519)	http://www.t10.org/
SATA Serial ATA Rev. 3.3	sata-io.org
SMBIOS System Management BIOS Reference Specification, v3.3.0	DMTF SMBIOS
TPM Trusted Platform Module Specification, v1.2 and v2.0	trustedcomputinggroup.org
UEFI Unified Extensible Firmware Interface Specification, v2.7	uefi.org/specifications
PI Platform Initialization Specification, v1.7	
USB Universal Serial Bus v2.0 and SuperSpeed v3.0 (USB 3.1 Gen1)	USB Implementers Forum, Inc. https://usb.org/documents
NVMe Express Base Specification. Revision 2.0c	https://nvmexpress.org/specifications/
NVMe Command Set Specifications	
1. NVMe Express NVM Command Set Specification. Revision 1.1c	
2. NVMe Express Zoned Namespaces Command Set. Revision 1.0c	
3. NVMe Express® Key Value Command Set. Revision 1.0c	
NVMe Transport Specifications	
1. NVMe Express over PCIe Transport. Revision 1.0c	
2. NVMe Express RDMA Transport Revision. 1.0b	
3. NVMe Express TCP Transport. Revision 1.0c	
NVMe NVMe Express Management Interface. Revision 1.2c	
NVMe NVMe Boot Specification. Revision 1.0	

Appendix B: Additional resources

Topics:

- [Customer kits](#)
- [Documentation](#)

Customer kits

Dell Upgrades

It is not always possible to plan for new applications, future workloads, and business needs. Unleash the full power of your Dell Technologies Infrastructure. When budget does not permit the purchase of new servers, Dell Upgrades is a cost-effective method to repurpose and unleash the full power of existing server, storage, and networking infrastructure.

- Protect your mission-critical operations by using only genuine Dell OEM-validated Upgrades and the technical expertise of Dell ProSupport
- Flex and scale existing infrastructure by upgrading, adding memory or storage drives to cost-effectively and quickly meet new workloads and demands
- Dell Upgrades are the same peripheral commodities that your customer may improve or maintain their server after the initial point of sale

Upgrades portfolio

Table 37. Upgrade category



Dell Upgrade Category	Sample Picture	Dell Upgrade Category Offerings
<p>Memory</p> <p>Memory upgrades are essential for keeping your customers operating at peak performance as their business needs grow and their workloads increase. We tend to see strong demand for server memory because it is the easiest and most cost-effective way to improve system performance.</p>		<p>DDR5 4800 MT/s</p>
<p>Networking and Optics</p> <p>Our networking and optics components—network interface cards, transceivers, optical cables, and more—are key in today's data center environment, helping customers to improve bandwidth to better manage increase in workloads, devices, users, and interconnected systems.</p>		<p>NICs HBAs</p> <p>Transceivers (Opticals)</p> <p>Direct Attach cables</p>

Table 37. Upgrade category (continued)

Dell Upgrade Category	Sample Picture	Dell Upgrade Category Offerings
<p>Accessories</p> <p>Dell sells accessories like power supplies, cables and power cables, bezels, controller cards, and risers to complete the Dell Upgrades portfolio and redundancies.</p>		<ul style="list-style-type: none"> Controller cards Power supplies Cables Rail kits Bezels Riser Power cords

Upgrades reference links

- [Main Upgrades Page](#)
- [Customer Kit Selector](#)
- [Dell Parts Finder Tool](#) (Customer Facing Tool)

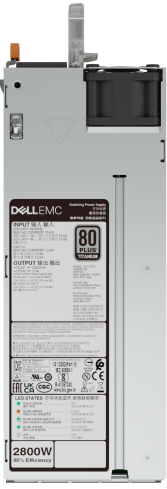
Documentation

This section provides information about the documentation resources for your system.

Table 38. Documentation resources

Document	Location
Factory Configuration Matrix	Sales Portal
SPM (Slot Priority Matrix)	Sales Portal
NDA Deck	Sales Portal
Installation and Service Manual (ISM)	https://www.dell.com/poweredgemanuals
Field Service Manual (FSM)	https://www.dell.com/poweredgemanuals > Sing in
Technical Guide	Dell.com > Product page > Product Details
Spec Sheet	Dell.com > Product page > Product Details

Appendix C: Additional specifications

Topics:

- Chassis dimensions
- System weight
- Video specifications
- USB ports specifications
- PSU rating
- Environmental specifications

Chassis dimensions

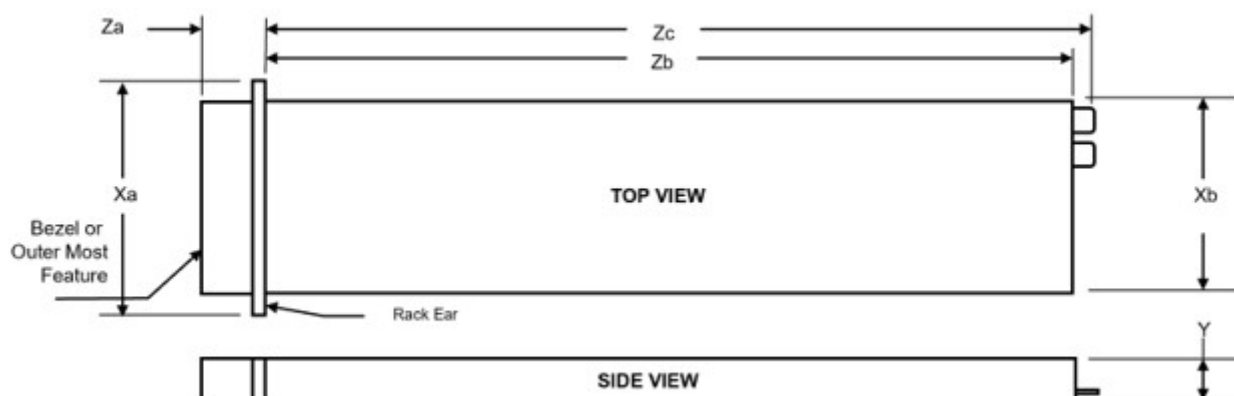

Figure 21. Chassis dimensions

Table 39. Chassis dimension for the PowerEdge XE9640 system

Drives	Xa	Xb	Y	Za	Zb	Zc
4 x 2.5-inch NVMe drives configuration	482 mm (18.97 inches)	444 mm (17.48 inches)	86.8 mm (3.41 inches)	35.77 mm (1.4 inches) With bezel 22.0 mm (0.87 inches) Without bezel	850 mm (33.46 inches) Ear to rear wall	890.8 mm (35.07 inches) Ear to PSU handle

NOTE: Zb is the nominal rear wall external surface where the system board I/O connectors reside.

System weight

Table 40. Weight for the PowerEdge XE9640 system

System configuration	Maximum weight (with all drives/SSDs)
XE9640 system with Intel GPUs	43.2 kg (95.23 pounds)

Table 40. Weight for the PowerEdge XE9640 system (continued)

System configuration	Maximum weight (with all drives/SSDs)
XE9640 system with NVIDIA GPUs	46.3 kg (102.07 pounds)

Table 41. PowerEdge system weight handling recommendations

Chassis weight	Description
40 pounds - 70 pounds	Recommend two person to lift
70 pounds- 120 pounds	Recommend three person to lift
≥ 121 pounds	Recommend to use a server-lift

NOTE: The system is heavy therefore can slide over and cause damage during installation and removal from a higher position on the rack.

Video specifications

The system supports integrated Matrox G200 graphics controller with 16 MB of video frame buffer.

Table 42. Supported front video resolution options for the system

Resolution	Refresh rate (Hz)	Color depth (bits)
1024 x 768	60	8, 16, 32
1280 x 800	60	8, 16, 32
1280 x 1024	60	8, 16, 32
1360 x 768	60	8, 16, 32
1440 x 900	60	8, 16, 32
1600 x 900	60	8, 16, 32
1600 x 1200	60	8, 16, 32
1680 x 1050	60	8, 16, 32
1920 x 1080	60	8, 16, 32
1920 x 1200	60	8, 16, 32

Table 43. Supported rear video resolution options for the system

Resolution	Refresh rate (Hz)	Color depth (bits)
1024 x 768	60	8, 16, 32
1280 x 800	60	8, 16, 32
1280 x 1024	60	8, 16, 32
1360 x 768	60	8, 16, 32
1440 x 900	60	8, 16, 32
1600 x 900	60	8, 16, 32
1600 x 1200	60	8, 16, 32
1680 x 1050	60	8, 16, 32
1920 x 1080	60	8, 16, 32
1920 x 1200	60	8, 16, 32

USB ports specifications

Table 44. PowerEdge XE9640 USB specifications

Front		Rear	
USB port type	No. of ports	USB port type	No. of ports
USB 2.0-compliant port	One	USB 3.0-compliant port	One
iDRAC Direct port (Micro-AB USB 2.0-compliant port)	One	USB 2.0-compliant ports	One

NOTE: The micro USB 2.0 compliant port can only be used as an iDRAC Direct or a management port.

PSU rating

Below table lists the power capacity the PSUs in High/Low line operation mode.

Table 45. PSUs Highline and Lowline Ratings

-	2800 W Titanium
Peak Power (High line AC/240 VDC)	4760 W
High line AC/ 240 VDC	2800 W
Peak Power (Lowline/-40 VDC)	N/A
Lowline/-40 VDC	N/A
Highline 240 VDC	2800 W
DC-48-60 V	N/A

The PowerEdge XE9640 supports four of AC or DC power supplies.

Dell PSUs have achieved Titanium efficiency levels as shown in the table below.

Table 46. PSU Efficiency Level

Form Factor	Output	Class	10%	20%	50%	100%
Redundant 86mm	2800 W	Titanium	90.00%	94.00%	96.00%	94%

Environmental specifications

NOTE: For additional information about environmental certifications, refer to the *Product Environmental Datasheet* located with the Manuals & Documents on www.dell.com/support/home.

Table 47. Operational climatic range category A2

Temperature	Specifications
Allowable continuous operations	
Temperature ranges for altitudes <= 900 m (<= 2953 ft)	10–35°C (50–95°F) with no direct sunlight on the equipment
Humidity percent ranges (non-condensing at all times)	8% RH with -12°C minimum dew point to 80% RH with 21°C (69.8°F) maximum dew point

Table 47. Operational climatic range category A2 (continued)

Temperature	Specifications
Operational altitude de-rating	Maximum temperature is reduced by 1°C/300 m (33.8°F/984 Ft) above 900 m (2953 Ft)

i **NOTE:** Certain system hardware configurations may require operating temperatures to be less than 28°C. For more information, see the Thermal air restrictions section.

Table 48. Shared requirements across all categories

Temperature	Specifications
Allowable continuous operations	
Maximum temperature gradient (applies to both operation and non-operation)	20°C in an hour* (36°F in an hour) and 5°C in 15 minutes (41°F in 15 minutes), 5°C in an hour* (41°F in an hour) for tape i NOTE: * - Per ASHRAE thermal guidelines for tape hardware, these are not instantaneous rates of temperature change.
Non-operational temperature limits	-40 to 65°C (-104 to 149°F)
Non-operational humidity limits	5% to 95% RH with 27°C (80.6°F) maximum dew point
Maximum non-operational altitude	12,000 meters (39,370 feet)
Maximum operational altitude	3,048 meters (10,000 feet)

Table 49. Maximum vibration specifications

Maximum vibration	Specifications
Operating	0.21 G _{rms} at 5 Hz to 500 Hz (all operation orientations)
Storage	1.88 G _{rms} at 10 Hz to 500 Hz for 15 minutes

Table 50. Maximum shock pulse specifications

Maximum shock pulse	Specifications
Operating	Six consecutively executed shock pulses in the positive and negative x, y, and z axis of 6 G for up to 11 ms.
Storage	Executed one shock pulses of 71 G for up to 2 ms.

Appendix D: Service and support

Topics:

- [Default support levels](#)
- [Other services and support information](#)

Default support levels

This system offers 3 years Dell ProSupport Next Business Day (NBD), including 24x7 phone support and NBD parts and labor support.

Default deployment levels

This system offers **Prodeploy Plus Dell Server** including onsite hardware installation and software configuration. Optionally, the customer may choose to any of the factory or field deployment offers listed below.

Other services and support information

Dell Technologies Services include a wide, customizable range of service options to simplify the assessment, design, implementation, management and maintenance of IT environments and to help transition from platform to platform.

Depending on the current business requirements and correct level of service for customers, we provide factory, onsite, remote, modular, and specialized services that fit the customer requirements and budget. We will help with a little or a lot, based on the customers choice, and provide access to our global resources.

Dell deployment services

[Dell ProDeploy Infrastructure Suite](#)

ProDeploy Infrastructure Suite provides a variety of deployment offerings that satisfy a customer's unique needs. It is made up of 5 offers: ProDeploy Configuration Services, ProDeploy Rack Integration Services, Basic Deployment, ProDeploy, and ProDeploy Plus.

ProDeploy Infrastructure Suite for servers

Versatile choices for accelerated deployments

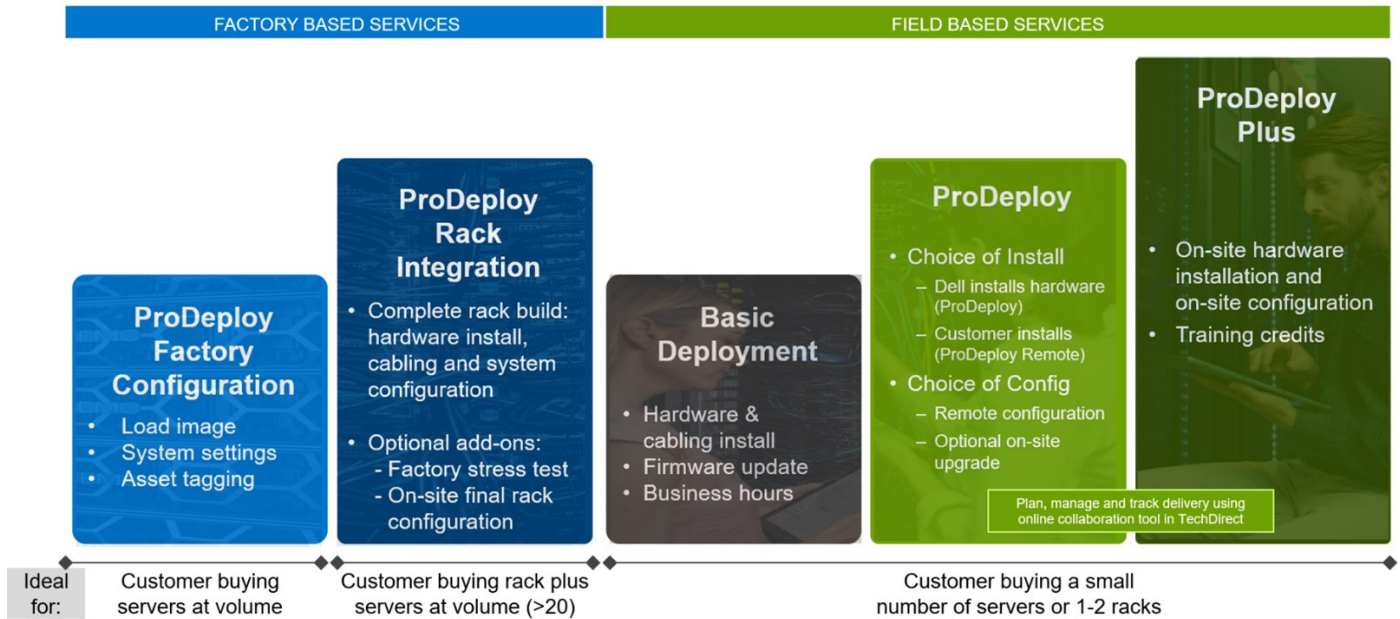

Figure 22. ProDeploy Infrastructure Suite for servers

The new Factory Services consist of two tiers of deployment that happen prior to shipping to the customer's site.

Factory Based Services:

- ProDeploy Factory Configuration - Ideal for customers buying servers in volume and seeking pre-configuration prior to shipping such as: custom image, system settings, and asset tagging so it arrives ready to use out of the box. Furthermore, servers can be packaged and bundled to meet specific shipping and distribution requirements for each customer location to facilitate the rollout process. Upsell one of the field based services (below) if a customer needs assistance with the final server installation.
- ProDeploy Rack Integration - Ideal for customers seeking to build out fully integrated racks prior to shipping. These rack builds include hardware install, cabling, and full system configuration. You can also add-on a factory stress test and optional on-site final rack configuration to complete the rack installation.
 - STANDARD SKUs for Rack Integration is available in US only and requires:
 - 20 or more devices (R and C series servers and all Dell or non-Dell switches). Use Informational SKUs for Dell switches or 3rd party products
 - Shipping to contiguous US
 - USE CUSTOM QUOTE for Rack Integration for:
 - All countries except USA
 - Racks containing less than 20 servers
 - Any rack that includes VxRail or Storage
 - Shipping outside contiguous US
 - Shipping to multiple locations

Field Based Services:

- Basic Deployment consists of the hardware installation, cabling and firmware update during normal standard business hours. Basic Deployment is traditionally sold to Competency Enabled Partners. Competency enabled partners often have Dell do the hardware installation while they complete the software configuration.
- ProDeploy consists of your hardware installation and configuration of the software using offshore resources. ProDeploy is great for customers who are price sensitive or who are remote from their data centers and don't require an onsite presence.
- ProDeploy Plus will give you in-region or onsite resources to complete the engagement for the customer. It also comes with additional features such as Post Deployment Configuration Assistance and Training Credits.

ProDeploy Infrastructure Suite | Factory services

FACTORY BASED SERVICES

		ProDeployFactory Configuration	ProDeploy Rack Integration
Asset configuration	Single point of contact for project management	●	●
	RAID, BIOS and iDRAC configuration	●	●
	Firmware freeze	●	●
	Asset Tagging and Reporting	●	●
	Customer system image	●	●
Factory implementation	Site readiness review and implementation planning	-	●
	Hardware racking and cabling	-	●
	SAM engagement for ProSupport Plus entitled accounts/devices	-	●
	Deployment verification, documentation, and knowledge transfer	●	●
Delivery	White glove logistics	-	●
	Onsite final configuration	-	Onsite add-on
	Install support software and connect with Dell Technologies	-	Onsite add-on
	Basic Deployment	Optional onsite installation	-
Online oversight	Online collaborative environment for planning, managing and tracking delivery	-	●

¹ ProDeployRack Integration Services are currently only available within the United States. Custom rack integration services are still available globally.*

Dell Technologies

Figure 23. ProDeploy Infrastructure Suite - Factory services

ProDeploy Infrastructure Suite | Field services

		Basic Deployment	ProDeploy	ProDeploy Plus
Pre-deployment	Single point of contact for project management	●	●	In-region
	Site readiness review	-	●	●
	Implementation planning ¹	-	●	●
	SAM engagement for ProSupport Plus entitled devices	-	-	●
Deployment	Deployment service hours	Business hours	24x7	24x7
	Onsite hardware installation and packaging material removal ² or remote guidance for hardware installation ¹	●	Remote guidance or onsite	Onsite
	Install and configure system software	-	Remote	Onsite
	Install support software and connect with Dell Technologies	-	●	●
	Project documentation with knowledge transfer	-	●	●
Post-deployment	Deployment verification	-	●	●
	Configuration data transfer to Dell Technologies technical support	-	●	●
	30-days of post-deployment configuration assistance	-	-	●
	Training credits for Dell Technologies Education Services	-	-	●
Online oversight	Online collaborative environment in TechDirect for planning, managing and tracking delivery ³	-	●	●

¹ Remote option includes project specific instructions, documentation and live expert guidance for hardware installation. Option available for select hardware. [List is available in the backup portion of this customer presentation](#)

² Packaging removal included with onsite hardware installation

³ Included with ProDeploy or ProDeploy Plus, Not included with Basic Deployment

Figure 24. ProDeploy Infrastructure Suite - Field services

Dell ProDeploy Plus for Infrastructure

From beginning to end, ProDeploy Plus provides the skill and scale that is must successfully perform demanding deployments in today's complex IT environments. Certified Dell experts start with extensive environmental assessments and detailed migration

planning and recommendations. Software installation includes set up of our enterprise connectivity solution (secure connect gateway) and OpenManage system management utilities.

Postdeployment configuration assistance, testing, and product orientation services are also available.

Dell ProDeploy for Infrastructure

ProDeploy provides full-service installation and configuration of both server hardware and system software by certified deployment engineers including set up of leading operating systems and hypervisors as well our enterprise connectivity solution (secure connect gateway) and OpenManage system management utilities. To prepare for the deployment, we conduct a site readiness review and implementation planning exercise. System testing, validation, and full project documentation with knowledge transfer complete the process.

Dell Basic Deployment

Basic Deployment delivers worry-free professional installation by experienced technicians who know Dell servers inside and out.

Additional Deployment Services

You can tailor the ProDeploy Infrastructure Suite offer to meet your customer's unique needs by leveraging "Additional Deployment Time." ADT will cover additional tasks above the normal scope of the standard offers. ADT can be sold for Project Management or Technical Resources and is sold as blocks of four hours remote or eight hours on-site.

Dell ProDeploy for HPC (available in US/Canada only. All other regions use custom)

HPC deployments require specialists that understand that cutting edge is yesterday's news. Dell deploys the world 's fastest systems and understands the nuances that make them perform. ProDeploy for HPC provides:

- Global team of dedicated HPC specialists
- Proven track record, thousands of successful HPC deployments
- Design validation, benchmarking, and product orientation

Learn more at Dell.com/HPC-Services.

ProDeploy Expansion for HPC

*Available as standard SKUs in US & Canada and as custom quote in APJC, EMEA, LATAM

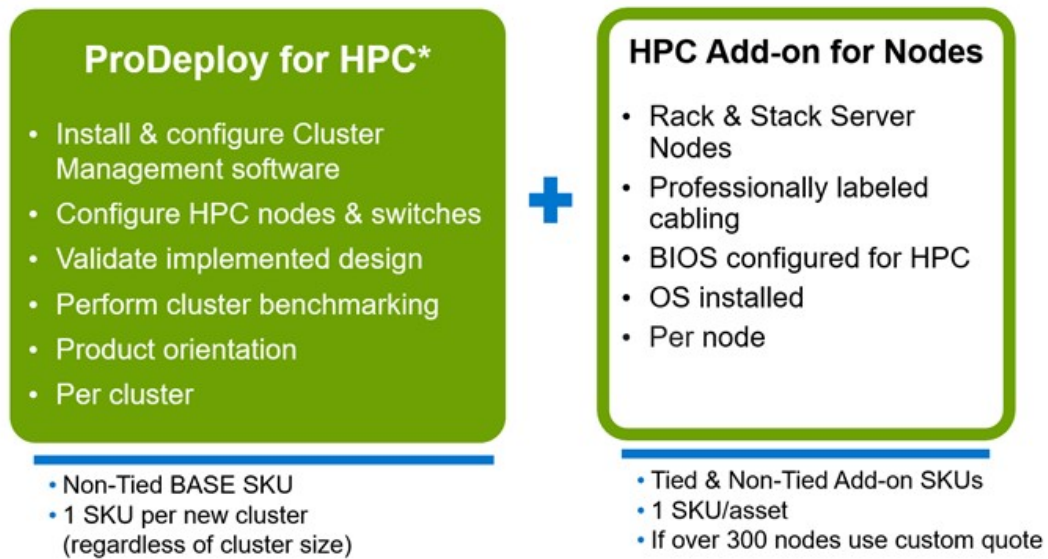

Figure 25. ProDeploy Expansion for HPC

Dell custom deployment Services

Dell custom rack integration and other Dell configuration services help customers save time by providing systems that are racked, cabled, tested, and ready to be integrated into the data center. Dell support preconfigure RAID, BIOS and iDRAC settings, install system images, and even install third-party hardware and software.

For more information, see [Server Configuration Services](#).

Dell Residency Services

Residency Services help customers transition to new capabilities quickly with the assistance of onsite or remote Dell experts whose priorities and time they control.

Residency experts can provide post implementation management and knowledge transfer that is related to a new technology acquisition or day-to-day operational management of the IT infrastructure.

Dell Data Migration Services

Protect business and data of the customer with our single point of contact to manage data migration projects.

A customer project manager works with our experienced team of experts to create a plan using industry-leading tools and proven processes that are based on global best practices to migrate existing files and data, so business systems are up and running quickly and smoothly.

Dell Enterprise Support Services

Dell ProSupport Enterprise Suite

With the ProSupport Enterprise Suite, we help keep IT systems running smoothly, so customers can focus on running their business. We help maintain peak performance and availability of the most essential workloads. ProSupport Enterprise Suite is a suite of support services that enable customers to build the solution that is right for their organization. They choose support models that are based on how they use technology and where they want to allocate resources. From the desktop to the data center, address everyday IT challenges, such as unplanned downtime, mission-critical needs, data and asset protection, support planning, resource allocation, software application management and more. Optimize customer IT resources by choosing the right support model.

Table 51. ProSupport Enterprise Suite

Service	Support model	Description
ProSupport Enterprise Suite	ProSupport Plus for Enterprise	Proactive, predictive, and reactive support for systems that look after your business-critical applications and workloads
	ProSupport for Enterprise	Comprehensive 24 x 7 predictive and reactive support for hardware and software
	Basic hardware support	Reactive hardware support during normal business hours

Dell ProSupport Plus for Enterprise

When customers purchase PowerEdge server, we recommend ProSupport Plus, our proactive and preventative support service for business-critical systems. ProSupport Plus provides all the benefits of ProSupport, plus the following:

- An assigned Services Account Manager who knows their business and environment
- Immediate advanced troubleshooting from an engineer
- Personalized, preventive recommendations that are based on analysis of support trends and best practices from across the Dell Technologies infrastructure solutions customer base to reduce support issues and improve performance
- Predictive analysis for issue prevention and optimization that is enabled by secure connect gateway technology
- Proactive monitoring, issue detection, notification, and automated case creation for accelerated issue resolution enabled by secure connect gateway
- On-demand reporting and analytics-based recommendations that are enabled by secure connect gateway and TechDirect

Dell ProSupport for Enterprise

ProSupport service offers highly trained experts around the clock and around the globe to address IT needs. We help minimize disruptions and maximize availability of PowerEdge server workloads with:

- 24x7 support through phone, chat and online
- Predictive, automated tools and innovative technology
- A central point of accountability for all hardware and software issues
- Collaborative third-party support
- Hypervisor, operating system and application support
- Consistent experience regardless of where customers are located or what language they speak

 **NOTE:** Subject to service offer country or region availability.

- Optional onsite parts and labor response options including next business day or four-hour mission critical

ProSupport Enterprise Suite Feature Comparison			
	Basic	ProSupport	ProSupport Plus
Remote technical support	9x5	24x7	24x7
Covered products	Hardware	Hardware Software	Hardware Software
Onsite hardware support	Next business day	Next business day or 4hr mission critical	Next business day or 4 hr mission critical
3 rd party collaborative assistance		●	●
Self-service case initiation and management		●	●
Access to software updates		●	●
Proactive storage health monitoring, predictive analytics and anomaly detection with CloudIQ and the CloudIQ mobile app		●	●
Priority access to specialized support experts			●
Predictive detection of hardware failures			●
3 rd party software support			●
An assigned Service Account Manager			●
Proactive, personalized assessments and recommendations			●
Proactive systems maintenance			●

Availability and terms of Dell Technologies Services vary by region and by product. For more information, please view our [service descriptions](#).

Internal Use - Confidential 23 of 117 © Copyright 2022 Dell Inc. **DELL** Technologies

Figure 26. ProSupport Enterprise Suite

Dell ProSupport One for Data Center

ProSupport One for Data Center offers flexible site-wide support for large and distributed data centers with more than 1,000 assets. This offering is built on standard ProSupport components that leverage our global scale but are tailored to a customer's needs. While not for everyone, this service option offers a truly unique solution for Dell Technologies largest customers with the most complex environments.

- Team of assigned Services Account Managers with remote, on-site options
- Assigned ProSupport One technical and field engineers who are trained on the customer's environment and configurations
- On-demand reporting and analytics-based recommendations that are enabled by secure connect gateway and TechDirect
- Flexible on-site support and parts options that fit their operational model
- A tailored support plan and training for their operations staff

Dell ProSupport Add-on for HPC

The ProSupport Add-on for HPC provides solution-aware support including:

- Access to senior HPC experts
- Advanced HPC cluster assistance: performance, interoperability, and configuration
- Enhanced HPC solution level end-to-end support
- Remote presupport engagement with HPC Specialists during ProDeploy implementation

Learn more at Dell.com/HPC-Services.

ProSupport Add-on for HPC is an add-on to PS or PSP

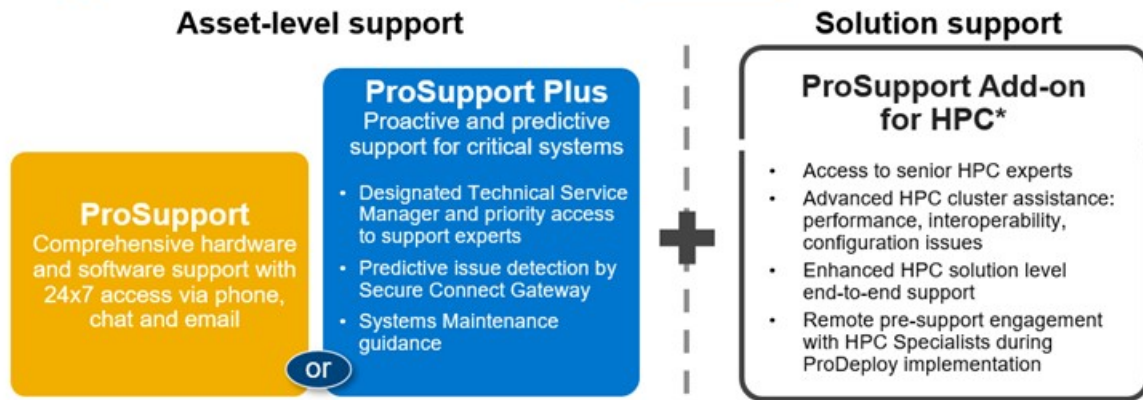

Eligibility

- All server, storage, and networking nodes in cluster must have PS or PSP **AND** PS Add-on for HPC attached
- All HW expansions to clusters must attach PS or PSP **AND** PS Add-on for HPC
- To retrofit an entire existing cluster with PS Add-on for HPC:
 1. HPC Specialists must review and validate the existing cluster
 2. PS or PSP **AND** the PS Add-on for HPC (APOS) must be attached to all server, storage and networking nodes

*Available in standard SKUs in NA and EMEA and as custom quote in APJC & LATAM

DELLTechnologies

Figure 27. ProSupport Add-on for HPC is an add-on to PS or PSP

Support Technologies

Powering the support experience with predictive, data-driven technologies.

NOTE: SupportAssist Enterprise capabilities are now part of the secure connect gateway technology.

Enterprise connectivity

The best time to solve a problem is before it happens. The automated proactive and predictive support features enabled by the secure connect gateway technology helps reduce steps and time to resolution, often detecting issues before they become a crisis. The gateway technology is available in virtual and application editions. It is also implemented as a direct connect version for select Dell hardware and a Services plugin within OpenManage Enterprise for PowerEdge servers. The legacy SupportAssist Enterprise solution has been retired and is now replaced by the secure connect gateway solutions.

Benefits include:

- Value: Our connectivity solutions are available to all customers at no additional charge
- Improve productivity: Replace manual, high-effort routines with automated support
- Accelerate time to resolution: Receive issue alerts, automatic case creation, and proactive contact from Dell experts
- Gain insight and control: Optimize enterprise devices with insights in portals reporting like TechDirect, and get predictive issue detection before the problem starts

NOTE: Connect devices can access these features. Features vary depending on the service level agreement for the connected device. ProSupport Plus customers experience the full set of automated support capabilities.

Table 52. Features enabled by connectivity

	Basic hardware warranty	ProSupport	ProSupport Plus
Automated issue detection and system state information collection	Supported	Supported	Supported
Proactive, automated case creation and notification	Not supported	Supported	Supported

Table 52. Features enabled by connectivity (continued)

	Basic hardware warranty	ProSupport	ProSupport Plus
Predictive issue detection for failure prevention	Not supported	Not supported	Supported

Get started at DellTechnologies.com/secureconnectgateway.

Dell TechDirect

TechDirect helps boost IT team productivity when supporting Dell systems.

Boost your productivity with online service for Dell products from TechDirect. From deployment to technical support, TechDirect lets you do more with less effort and faster resolution. You can:

- Open and manage support requests or in-warranty systems
- Execute online self-service for parts dispatch
- Collaborate on ProDeploy infrastructure deployment projects online
- Manage proactive and predictive alerts from secure connect gateway technology that help maximize uptime
- Integrate services functionality into your help desk with TechDirect APIs
- Join over 10,000 companies that choose TechDirect

Register at TechDirect.Dell.com.

Dell Technologies Consulting Services

Our expert consultants help customers transform faster, and quickly achieve business outcomes for the high value workloads Dell PowerEdge systems can handle. From strategy to full-scale implementation, Dell Technologies Consulting can help determine how to perform IT, workforce, or application transformation. We use prescriptive approaches and proven methodologies that are combined with portfolio and partner ecosystem of Dell Technologies to help achieve real business outcomes. From multi cloud, applications, DevOps, and infrastructure transformations, to business resiliency, data center modernization, analytics, workforce collaboration, and user experiences-we are here to help.

Dell Managed Services

Some customers prefer Dell to manage the complexity and risk of daily IT operations, Dell Managed Services utilizes proactive, AI enabled delivery operations and modern automation to help customers realize desired business outcomes from their infrastructure investments. With these technologies, our experts run, update and fine-tune customer environments aligned with service levels, while providing environment-wide and down-to-the-device visibility. There are two types of managed service offers. First the outsourcing model or CAPEX model where Dell manages the customer owned assets using our people and tools. The second is the as-a-Service model or OPEX model called APEX. In this service, Dell owns all technology and all the management of it. Many customers will have a blend of the two management types depending on the goals of the organization.

Managed	Outsourcing or CAPEX model	APEX	as-a-Service or OPEX model
<p>We manage your technology using our people and tools.¹</p> <ul style="list-style-type: none"> • Managed detection and response* • Technology Infrastructure • End-user (PC/desktop) • Service desk operations • Cloud Managed (Pub/Private) • Office365 or Microsoft Endpoint 		<p>We own all technology so you can off-load all IT decisions.</p> <ul style="list-style-type: none"> • APEX Cloud Services • APEX Flex on Demand elastic capacity • APEX Data Center Utility pay-per-use model 	

1 – Some minimum device counts may apply. Order via: ClientManagedServices.sales@dell.com

* Managed detection and response covers the security monitoring of laptops, servers, & virtual servers. Min. 50 devices combined. No Networking or Storage-only systems [SAN/NAS]. Available in 32 countries. [Details here](#)

Figure 28. Dell Managed Services

Dell Technologies Education Services

Build the IT skills required to influence the transformational outcomes of the business. Enable talent and empower teams with the right skills to lead and perform transformational strategy that drives competitive advantage. Leverage the training and certification required for real transformation.

Dell Technologies Education Services offers PowerEdge server training and certifications that are designed to help customers achieve more from their hardware investment. The curriculum delivers the information and the practical, firsthand skills that their team must confidently install, configure, manage, and troubleshoot Dell servers.

To learn more or register for a class today, see Education.Dell.com.