

Dell PowerEdge XE9712

Technical Guide

Notes, cautions, and warnings

 **NOTE:** A NOTE indicates important information that helps you make better use of your product.

 **CAUTION:** A CAUTION indicates either potential damage to hardware or loss of data and tells you how to avoid the problem.

 **WARNING:** A WARNING indicates a potential for property damage, personal injury, or death.

Chapter 1: Dell PowerEdge XE9712 system configurations and features	5
Key workloads.....	5
New technologies.....	5
System features	6
Chapter 2: Chassis views and features	8
Front view of the system.....	8
Rear view of the system.....	8
Inside the system.....	9
Chapter 3: Power Shelf overview	11
Chapter 4: Power whips	13
Key components of a power whip.....	13
Types of power whips.....	13
Power whip specifications.....	13
Benefits of power whips in IT racks.....	13
Installation and best practices.....	13
Chapter 5: Dell Integrated Rack Controller	15
Chapter 6: Management switch overview	16
Chapter 7: Switch overview	17
Chapter 8: Rack Power Distribution Unit (rPDU)	18
Chapter 9: Memory subsystem	19
Supported memory.....	19
Chapter 10: Storage	20
Storage Configuration.....	20
Chapter 11: PCIe subsystem	21
PCIe subsystem overview.....	21
PCIe risers and slots.....	21
Chapter 12: Data Processing Units	22
Overview.....	22
DPUs.....	22
Chapter 13: Coolant Distribution Unit (CDU)	23

Chapter 14: Capacitor Shelf overview.....	25
Chapter 15: Networking.....	26
Overview.....	26
Mezzanine cards.....	26
Chapter 16: Thermal Restrictions.....	27
Chapter 17: Rack, rails, and cable management.....	29
Rails.....	29
Chapter 18: Operating Systems and Virtualization.....	32
Supported operating systems.....	32
Chapter 19: Appendix A: Additional specifications.....	33
Processor specifications.....	33
Chassis dimensions	33
System weight.....	34
GPU Specifications.....	34
NIC port Specifications.....	34
Video specifications.....	34
Environmental specifications.....	34
Particulate and gaseous contamination specifications.....	36
Chapter 20: Appendix B. Standards compliance.....	37
Chapter 21: Appendix C: Additional resources.....	38
Chapter 22: Appendix D: Service and support.....	39
Why attach service contracts.....	39
ProSupport Infrastructure Suite	39
Specialty Support Services.....	40
ProDeploy Infrastructure Suite.....	42
Supplemental Deployment Services	43
DAY 2 – Automation Services with Ansible.....	43
Dell Technologies Consulting Services.....	44

Dell PowerEdge XE9712 system configurations and features

The Dell PowerEdge XE9712 is a 2-socket, 1RU (rack unit) sled that supports:

- Two NVIDIA Grace Ultra Processors with up to 72 cores per processor
- 480 GB of LPDDR5 memory with error-correction code (ECC)
- Up to 4 GPUs per sled with 288 GB HBM3e/GPU
- CPU-GPU Interconnection: NVLink-C2C: 900 GB of coherent memory
- Up to 2 PCIe Gen5 slots with BF3-3240 cards
- M.2 Riser, DPU, BlueField-3 (BF3), Octal Small Form-factor Pluggable (OSFP)
- Up to 8 x E1.S NVMe direct drives
- NVIDIA BMC and ref Boot FW

NOTE: 1 RU = 44.45 mm (1.75 in.) height, and 482.6 mm (19 in) width.

NOTE: The speed of E1.S drives is also dependent on the storage controller capability and not just the drive speed.

CAUTION: Do not install GPUs, network cards, or other PCIe devices on your system that are not validated and tested by Dell. Damage caused by unauthorized and invalidated hardware installation will null and void the system warranty.

Topics:

- [Key workloads](#)
- [New technologies](#)
- [System features](#)

Key workloads

The key workloads for XE9712 are :

- Large Language Models- LLM Training
- Large Language Models- LLM Inference
- Large Scale AI Training
- Rack Scale Architecture
- Grace Blackwell GPU NVL72

New technologies

The PowerEdge XE9712 can handle demanding workloads and applications, such as high-performance computing (HPC), high-frequency trading, digital visual effects, and animation.

Table 1. New technologies

Technology	Detailed Description
Processor	Two NVIDIA Grace with 72 cores per processor
	Speeds up to 3.6 GHz
	Maximum TDP: 500 W

Table 1. New technologies (continued)

Technology	Detailed Description
Memory	480 GB of LP DDR5X memory with error-correction code (ECC) / CPU
	288 GB HBM3e/GPU
PCIe Gen	Gen5/Gen6 @32 GT/s
PCIe Slot	Supports 1 x BF3
Flex I/O	Front I/O with DC-SCM card : <ul style="list-style-type: none"> • 1 x USB 3.0 Type - A port • 1 x BIOS Serial out • 1 x RJ45 dedicated BMC port • 1 x Mini-Display Port • 1 x 1Gb LOM

System features

The following table shows the features of the PowerEdge XE9712.

Table 2. System features

Features	PowerEdge XE9712
Processors	Two NVIDIA Grace per tray with 72 cores per processor
Memory	<ul style="list-style-type: none"> • CPU memory: 480 GB of LPDDR5X memory with error-correction code (ECC)/CPU DIMM Speed. • GPU memory: 288 GB HBM3e/GPU
CPU-GPU Interconnection	<ul style="list-style-type: none"> • Cabled 6 x C-Links CPU-CPU, fixed CPU-CPU coherent links • Up to 10 NVLink-C2C: 900GB/s of coherent memory of CPU-GPU interconnection
Storage Controllers	<ul style="list-style-type: none"> • BF3-B3240 x 1
Front Bays	Up to 8 x EDSFF E1.S hot-swappable NVMe drives
Integrated Rack solution	IR9048 ORv3 (OCP Open Rack version 3)
Cooling features	<ul style="list-style-type: none"> • Air Cooling • Direct Liquid Cooling (DLC)
Power supplies	<ul style="list-style-type: none"> • IR9048 rack consists of Power Shelf 33kW (PS33) that supports 6 x 5500 W AC PSUs • PS33 supplies up to 54 VDC to the XE9712 through Power bus bar on IR9048 rack
Fans	Eight standard cooling fans
XE9712 Dimensions and Weight	Height: 43.6 mm (1.72 inches)
	Width: 438 mm (17.24 inches)
	Depth: 807 mm (31.77 inches)
	Weight: 30 kg (66.14 pounds)
IR9048 Dimensions and Weight	Height: 2286 mm (90 inches)
	Width: 750 mm (29.52 inches)
	Depth: 1200 mm (47.24 inches)

Table 2. System features (continued)

Features	PowerEdge XE9712
	Depth: 1340 mm (57.75 inches) with stabilizers Wet Weight: 1590 kg (3505.35 pounds)
Form Factor	<ul style="list-style-type: none"> ● IR9048 = 48 RU (Rack Units) ● XE9712 is 1 RU ⓘ NOTE: 1 RU = 44.45 mm (1.75 inch) height, and 538.98 mm (21.22 inch) width.
Embedded Management	<ul style="list-style-type: none"> ● Aspeed AST2600 BMC DC-SCI compatible ● OpenBMC ● BMC-to-NVIDIA HMC for HPM management
Networking Options	<ul style="list-style-type: none"> ● Each dual CX8 mezz support 2 x 800Gb/s OSFP ● 1 x 1G System LAN ● 1 x BMC management LAN ● 1 x BF3 B3240 = Bluefiled-3 which supports up to 400Gb/s QSFP
GPU Options	<ul style="list-style-type: none"> ● 4 x GPU rear NVLink5 connectors to Non-Scalable NVS array
DPU	<ul style="list-style-type: none"> ● Up to 1 x DPU per node up to 150W, DPU aux power cable support
Ports	<ul style="list-style-type: none"> ● 1 x USB 3.0 Type - A port ● 1 x BIOS Serial out ● 1 x RJ45 dedicated BMC port / management port ● 1 x Mini-Display Port ● 1 x 1Gb LOM ● 4 x OSFP
PCIe slots and Risers	<ul style="list-style-type: none"> ● One FH HL Gen5, front riser only ● 2 x Mezzanine - Gen5/Gen6
PCIe cards	<ul style="list-style-type: none"> ● BF3 B3240 Super-NIC Full Height Half Length
Boot devices	M.2 boot riser
Rail support	Static rails for ORv3 IR9048 rack
Operating System and Hypervisors	<ul style="list-style-type: none"> ● GraceOS (NVIDIA qualified OS) For specifications and interoperability details, see Dell Enterprise Operating Systems on Servers, Storage, and Networking page at Dell.com/OSsupport .
Thermal solution	Liquid to Liquid CDU

Chassis views and features

Topics:

- Front view of the system
- Rear view of the system
- Inside the system

Front view of the system

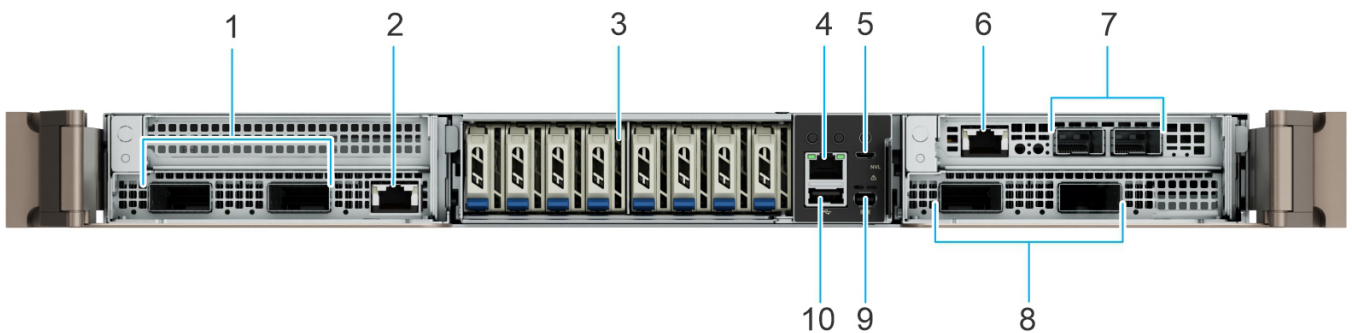

Figure 1. Front view of the system

1. CX8 OSFP ports
2. 1 Gb LOM port
3. E1.S drives
4. BMC port
5. UART
6. BF3 RJ45 MGMT port
7. BF3 ports
8. CX8 OSFP ports
9. Mini-Display port
10. USB 3.0 port

Rear view of the system

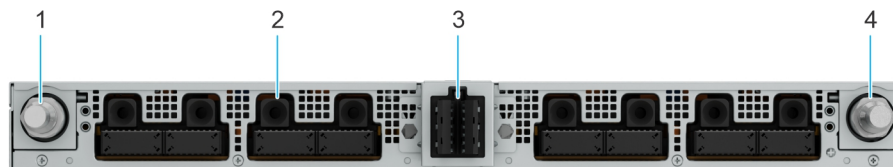

Figure 2. Rear view of the system

Table 3. Rear view of the system

Item	Ports, panels, or slots	Description
1	Rear Quick Disconnect outlet	Enables the coolant liquid to flow out of the system to the DLC manifold on the rack.
2	NVLink connector	The NVLink connector enables high-speed, direct GPU-to-GPU communication.
3	Power bus bar connector	Enables sled to get power supply from the power bus bar on the rack.
4	Rear Quick Disconnect inlet	Enables the coolant liquid to flow into the system from the DLC manifold on the rack.

Inside the system

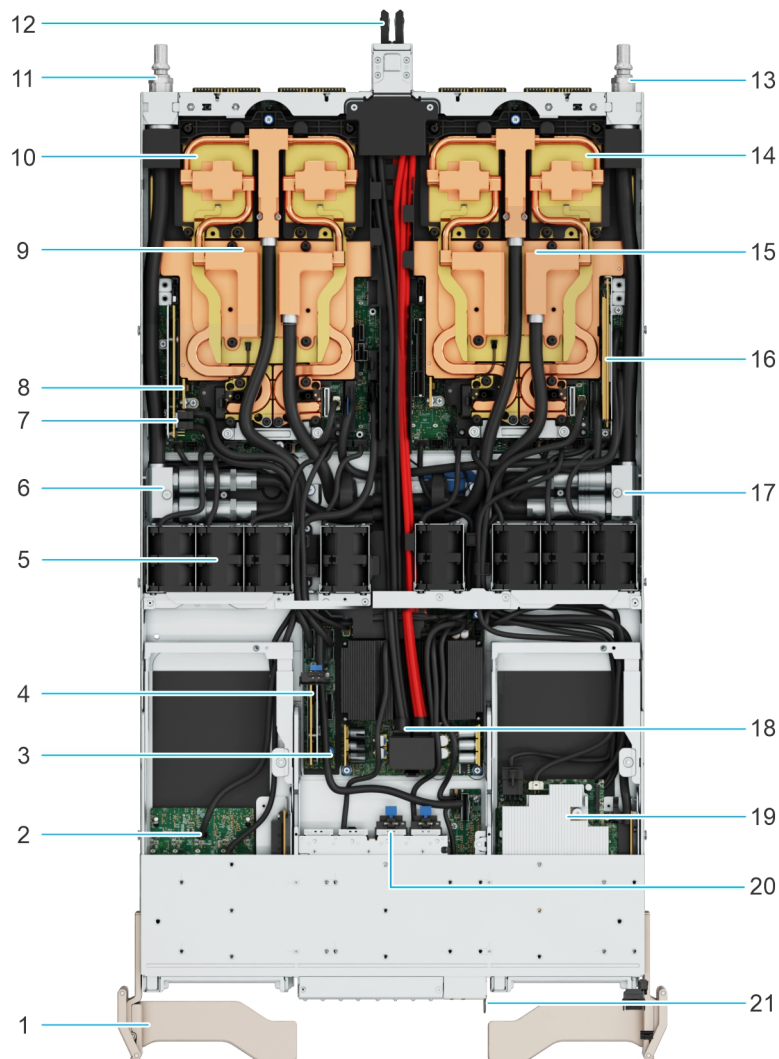

Figure 3. Inside the system

- | | |
|--|---|
| 1. Cam lever | 2. OSFP module |
| 3. Management interposer | 4. BMC |
| 5. Cooling fan | 6. Inner manifold and leak sensors |
| 7. HMC module | 8. TPM module |
| 9. GB300/HPM | 10. GPU + CPU cold plate and leak sensors |
| 11. Rear Quick Disconnects (QDs) - Inlet | 12. Busbar connector - 54V |
| 13. Rear QDs - Outlet | 14. GPU + CPU cold plate and leak sensors |

- 15. GB300/HPM
- 17. Inner manifold and leak sensors
- 19. PCIe card (right bay)
- 21. Luggage tag

- 16. M.2 riser module
- 18. PDB
- 20. E1 backplane

Power Shelf overview

The Power Shelf's 5500 W power supply units provide power. They supply 54 V DC output to the power busbar for compute nodes and other components that are installed in the rack.

Power Shelf feature and specifications

- High Efficiency 5.5 kW PSU; 97.5% peak / 96.5% at full load
- Hot-pluggable Power Management Controller for monitoring and control
- DC output selects power clip for quick connection to rack power busbar

Table 4. Power Shelf output

Output	
Output power	33 kW
Output voltage (no load/ full load)	49 V / 50 V
Output current	674 A

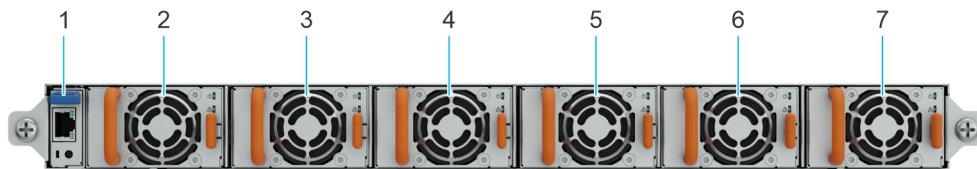

Figure 4. Front view of 19 inch Power Shelf

- | | |
|--------------------------------------|---------|
| 1. Power Management Controller (PMC) | 2. PSU1 |
| 3. PSU2 | 4. PSU3 |
| 5. PSU4 | 6. PSU5 |
| 7. PSU6 | |

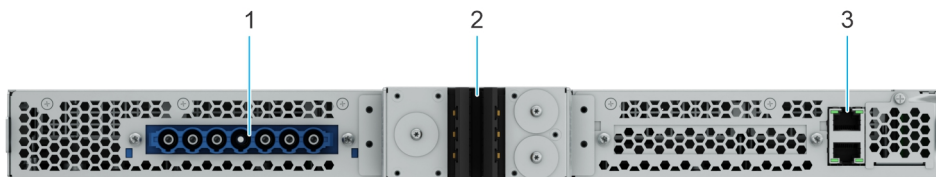

Figure 5. Rear view of 19 inch Power Shelf

1. Power whip connector/Input
2. PSU busbar connector/Output
3. RJ45 ports

Main input connection

The Power Shelf has a 7 pin 60 A AC input connector.

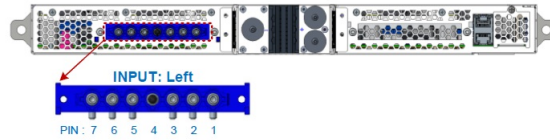

Figure 6. Power Shelf input connector

Input fusing

The shelf does not provide any input fusing. Upstream Circuit Breaker with 60 A per phase is recommended.

Main output connector

The Power Shelf has a clip connector to mate with the 48 V busbars which are mounted in the rack. The clip has a 3 mm floating ability, which can make up for unaligned amount on busbars.

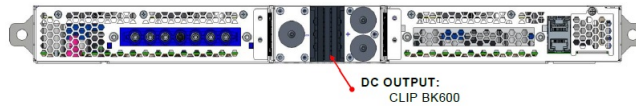

Figure 7. Power Shelf output connector

Hot plug

The Controller is hot unplugged and hot plugged during Shelf operation. The Shelf continues operating without interruption. If a catastrophic fault occurs, the Hot plug controller has an internal OCP protection.

Power whips

A Power Whip is a high-voltage electrical cable assembly that is used to distribute power from a Power Distribution Unit (PDU) to IT equipment within a data center rack. It plays a crucial role in ensuring efficient and safe power delivery to servers, switches, and other critical components.

Topics:

- [Key components of a power whip](#)
- [Types of power whips](#)
- [Power whip specifications](#)
- [Benefits of power whips in IT racks](#)
- [Installation and best practices](#)

Key components of a power whip

- **Conduit** : Protects the internal wiring from damage and interference.
- **Conductors (Wires)** : Typically made of copper or aluminum to carry electrical current.
- **Connectors** : Custom-fitted to PDUs and power outlets to ensure secure connections.
- **Jacket** : Insulated covering for safety and durability.

Types of power whips

- **Flexible Metal Conduit (FMC)** : Provides flexibility in cable routing.
- **Liquid-Tight Flexible Metal Conduit (LFMC)** : Offers moisture resistance for damp environments.
- **Rigid Metal Conduit (RMC)** : Used for high-security installations requiring extra protection.

Power whip specifications

- **Voltage Ratings** : Commonly available in 120 V, 208 V, 240 V, or higher for data centers.
- **Ampere Ratings** : Typically ranges from 15A to 60A, depending on power requirements.
- **Phase Configuration** : Can be single-phase or three-phase for higher power efficiency.
- **Length** : Varies based on rack layout and distance from the PDU.

Benefits of power whips in IT racks

- **Reliable Power Distribution** : Ensures consistent power delivery to critical IT equipment.
- **Reduced Cable Clutter** : Helps maintain an organized rack setup.
- **Customization** : Available in different configurations to match PDU and equipment needs.
- **Safety Compliance** : Designed to meet electrical codes and standards for safe operation.

Installation and best practices

- Ensure that power whips are rated for the rack's voltage and amperage requirements.
- Properly secure conduits to avoid strain on connections.
- Maintain adequate airflow around cables to prevent overheating.

 **NOTE:** Regularly inspect for wear and replace damaged power whips to prevent failures.

Dell Integrated Rack Controller

Table 5. Dell Integrated Rack Controller features

Features	Description
Rapid Leak Reaction	Quickly detects leaks and enacts policies to minimize potential damage (fluid isolation, power shut down with OpenManage Enterprise)
Unparalleled Reliability	Always-on Detect, React, Inform (DRI), proactive health monitoring, and unified management with OpenManage Enterprise
Scalable	OpenManage Enterprise provides visibility to the entire data center at scale
Cooling Efficiency	Enables eRDHx to drive rack cooling efficiency

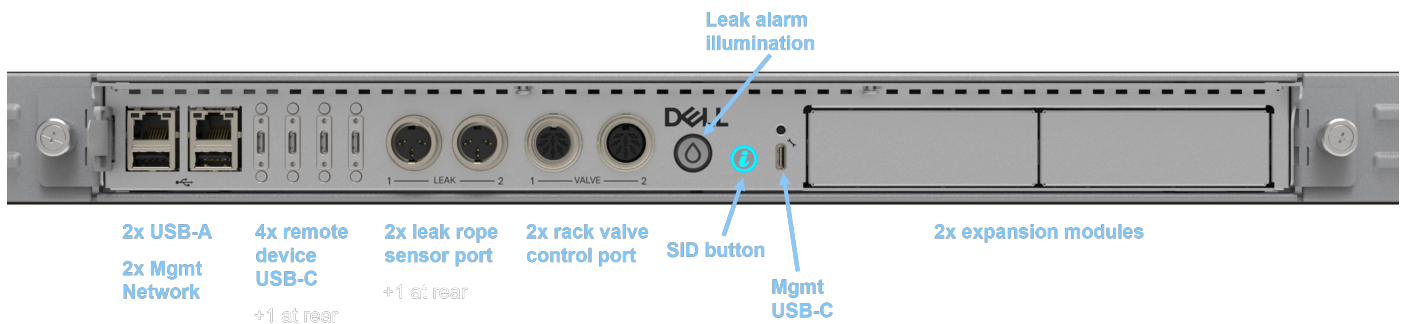

Figure 8. Dell Integrated Rack Controller

Integrated Rack controller supports the following on the rear side:

- 1 x USB-C
- 1 x Leak rope sensor port
- Backup fan
- Reset button and LED
- 2 x power ports

Management switch overview

The IR9048 is equipped with a management switch for networking within the rack with DELL SN2201-ON management switch.

Table 6. Management switch dimensions

Height	Width	Depth
43.9 mm (1.72 inch)	428 mm (16.84 inch)	432 mm (17 inch)



Figure 9. Management switch

Switch overview

The IR9048 supports SN2201 switch (NVIDIA Spectrum™).



Figure 10. SN2201 Switch

For more information on the switch, see [SN2201-datasheet](#).

Rack Power Distribution Unit (rPDU)

The IR9048 is supported a Vertiv VP4UU1A0 power distribution unit to provide power to the components installed in the rack.

Table 7. rPDU dimensions

Height	Width	Depth
44 mm (1.72 inch)	432 mm (17 inch)	229 mm (9.01 inch)

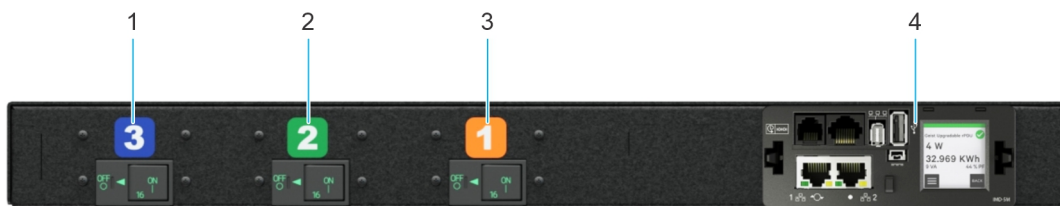

Figure 11. rPDU front view

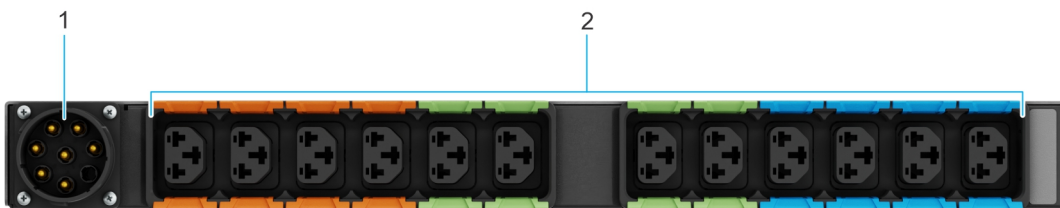

Figure 12. rPDU rear view

The rPDU has a universal inlet and plug form (3P+N+E) (IP44).

Memory subsystem

Topics:

- [Supported memory](#)

Supported memory

The XE9712 system supports 480 GB solder-down memory on HPM GB300.

Storage

Topics:

- [Storage Configuration](#)

Storage Configuration

M.2 Riser and card feature matrix

Table 8. M.2 Riser and card feature matrix

Riser card	Drive Size	RAID levels	Maximum drives supported	Drive types	PCIe support	Disk cache policy	Cryptographic digital signature to verify firmware payload
M.2 Riser Card	SSDs M.2 2280	Not Supported	1	2280 M.2 NVMe SSDs	Gen4 at 16 GB/s	Drive default	Drive default

PCIe subsystem

Topics:

- [PCIe subsystem overview](#)
- [PCIe risers and slots](#)

PCIe subsystem overview

The PowerEdge XE9712 supports up to two FHHL x16 slots.

PCIe risers and slots

Table 9. PCIe risers and slots

Riser	Riser Type	Controlling the CPU	Endpoints	Slot bandwidth	EP Type	Power(Watts)
RF2	cable riser	CPU 1	1	Gen5 x16	CEM	150W

Table 10. Expansion cards are supported on the front of the system

Riser: BlueField-3
One B3240

Table 11. M.2 boot and E1.S

Riser: M.2 boot	Note
Yes	Operating system in M2

Data Processing Units

Topics:

- [Overview](#)

Overview

Data Processing Units (DPUs) are the next disruptive technology in the data center that has a NIC ASIC along with ARM cores. They help offload and hardware accelerate infrastructure services of the data-centric accelerated computing model.

It is better explained as a system on a chip that combines:

- Industry-standard, high-performance, software-programmable multi-core CPU
- High performance network interface
- Flexible and programmable acceleration engines
- Accelerated storage and networking solutions

Two types of DPUs are offered: Dell managed and Vendor managed. The Dell managed DPUs supports full Dell system integration that can be managed with tools such as iDRAC. Vendor managed DPUs are managed with vendor provider tools.

The DPU matrix posted in knowledge portal is the central repository for both Dell and Vendor managed DPU information. The matrix covers:

- Part Numbers, Tied SKUs and Customer Kits
- Server Compatibility and Support
- Optics and Cable Support
- Systems Management
- Spec Sheet Links

This document is updated as changes happen, so be sure to bookmark it rather than downloading an offline copy or refer to [Data Processing Units Matrix](#) on sales portal.

DPUs

The system supports one DPU per node up to 150 W, DPU aux power cables.

Coolant Distribution Unit (CDU)

Liquid cooling components

- Coolant Distribution Units (CDU) for heat exchange with facility
- Rack manifold with hose kits
- DLC enabled compute trays and switch trays

Coolant distribution unit: The coolant distribution unit circulates coolant from the manifold to the NVlink switches and the GPU sleds.

Models

- In-Rack CDUs: Vertiv XDU100B or 121, or Delta LCHD124A4QA
- In-Row CDUs: Motivair MCDU-50 or Vertiv XDU 1350



Figure 13. Cooling Distribution Units (CDUs)- In-Rack



Motivair MCDU-50



Vertiv CDU-1350

Figure 14. Cooling Distribution Units (CDUs)- In-Row

Capacitor Shelf overview

The Delta Capacitor shelf is a component that connects electrically to the Bus Bar, storing and releasing energy as needed. It acts similarly to a battery, charging from and discharging back into the DC bus bar, and is designed to be hot-swappable, allowing for easy replacement without disrupting the system. It is mechanically secured via a PMC connection within the rack.

Table 12. Power capacitance shelf (PCS) specification

Feature	19inch Rack
Output voltage	52V
DCH/CHG	15 kW/15kW @ 5 sec
Air Flow	Front panel to rear Bark lip
Dimension LxWxH) (mm)	760 x 448 x 44.45 (1RU)
Output connector	BK500 (500 A)

Networking

Topics:

- [Overview](#)

Overview

PowerEdge offers a wide variety of options to get information moving to and from our servers. Industry best technologies are chosen and these adapters are rigorously validated for worry-free, fully supported use in Dell servers.

Mezzanine cards

The system supports IB Mezzanine NDR and XDR with GPU direct Gen6 x16, Super-NIC Mezzanine.

Thermal Restrictions

Table 13. PCIe Configuration Restriction

Max PCIe Q'ty/Per Sled	PCIe Slot #1	PCIe Slot #2
1	N/A	BF3 DPU card ((NVIDIA B3240, NVIDIA B3240)
2	CX8 PCIe card (NVIDIA C8180)	CX8 PCIe card (NVIDIA C8180)

NOTE:

1. NVIDIA Dual QSFP112 Transceiver (MMA1Z00-NS400) is required for BF3 DPU card.
2. NVIDIA Dual OSFP Transceiver (980-9IAT0-00XM00, MMS4X00-NM-FLT, MMS4X00-NS-FLT, MMA4Z00-NS-FLT) is required for CX8 PCIe card.

Table 14. Thermal restrictions

XE9712	Configuration	
I/O Board Configuration	CX8 x 2	
PCIe Configuration	C8180 x 2	Slot 2: B3240 x 1
E1.S SSD Configuration	G5 E1.S SSD x 2 (S0, S1)	Solidigm PS1010 E1.S SSD x 8
BOSS Configuration	960 GB M.2 NVMe x 1	

Table 15. TDP

XE9712	TDP	Total TDP	Model	Supported temperature
CPU TDP	300 W per HPM	2900 W per HPM	GB300 HPM 1CPU: 2GPU Board	40°C
GPU TDP	2 x 1400 W per HPM			

NOTE:

1. CPU can go up to 300 W max by borrowing power from GPUs.
2. NVIDIA Dual QSFP112 Transceiver (MMA1Z00-NS400) is required for BF3 DPU card.
3. NVIDIA Dual OSFP Transceiver (980-9IAT0-00XM00, MMS4X00-NM-FLT, MMS4X00-NS-FLT, MMA4Z00-NS-FLT) is required for CX8 OSFP board.

Blank requirement

E1.S slots must be fully populated or blanked.

- BF3-B3240 x 1 supports eight E1.S drives on all slots from S0 to S7.

Thermal solution

Table 16. Thermal solution – Fan

Vendor	Delta	AVC	Foxconn
Inlet Fan Speed (RPM)	33800 ± 10%	33600 ± 10%	34000 ± 10%

Table 16. Thermal solution – Fan (continued)

Vendor	Delta	AVC	Foxconn
Outlet Fan Speed (RPM)	31100 ± 10%	29200 ± 10%	32500 ± 10%
Max. Air Pressure (in-H2O)	11.66	11.32	11.14
Max. Air Flow (CFM)	45.64	41.16	45.17
Input Current (A)	4.00 (Max. 5.2)	4.80 (Max. 5.76)	3.45 (Max 4.15)
Operation Voltage (VDC)	10.8-13.2	10.8-13.2	10.8-13.2
Max Input Power (W)	48.00 (Max.62.40)	57.60 (Max. 69.12)	41.40 (Max 49.80)

Rack, rails, and cable management

Topics:

- Rails

Rails

The IR9048 supports multiple types of rails.

The IR9048 rack supports the following rails:

- Power Shelves rails



Figure 15. 19 inch Power Shelf rails

- Coolant distribution unit (CDU) rails

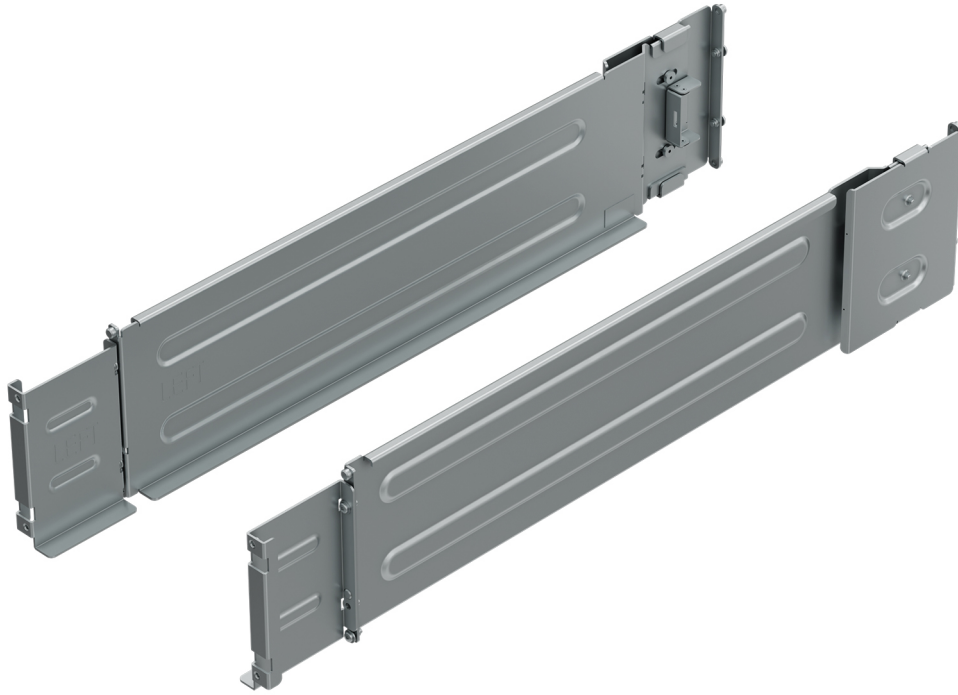

Figure 16. Coolant distribution unit (CDU) rails

- Sliding rails



Figure 17. Sliding rails

- Switch rails



Figure 18. Switch rails

Operating Systems and Virtualization

Topics:

- [Supported operating systems](#)

Supported operating systems

The XE9712 system supports the following operating systems:

- GraceOS

For specifications and interoperability details, see [OS support](#).

Appendix A: Additional specifications

Topics:

- Processor specifications
- Chassis dimensions
- System weight
- GPU Specifications
- NIC port Specifications
- Video specifications
- Environmental specifications

Processor specifications

Table 17. PowerEdge XE9712 processor specifications

Supported processor	Number of processors supported
NVIDIA Grace with 72 cores per processor	Two

Chassis dimensions

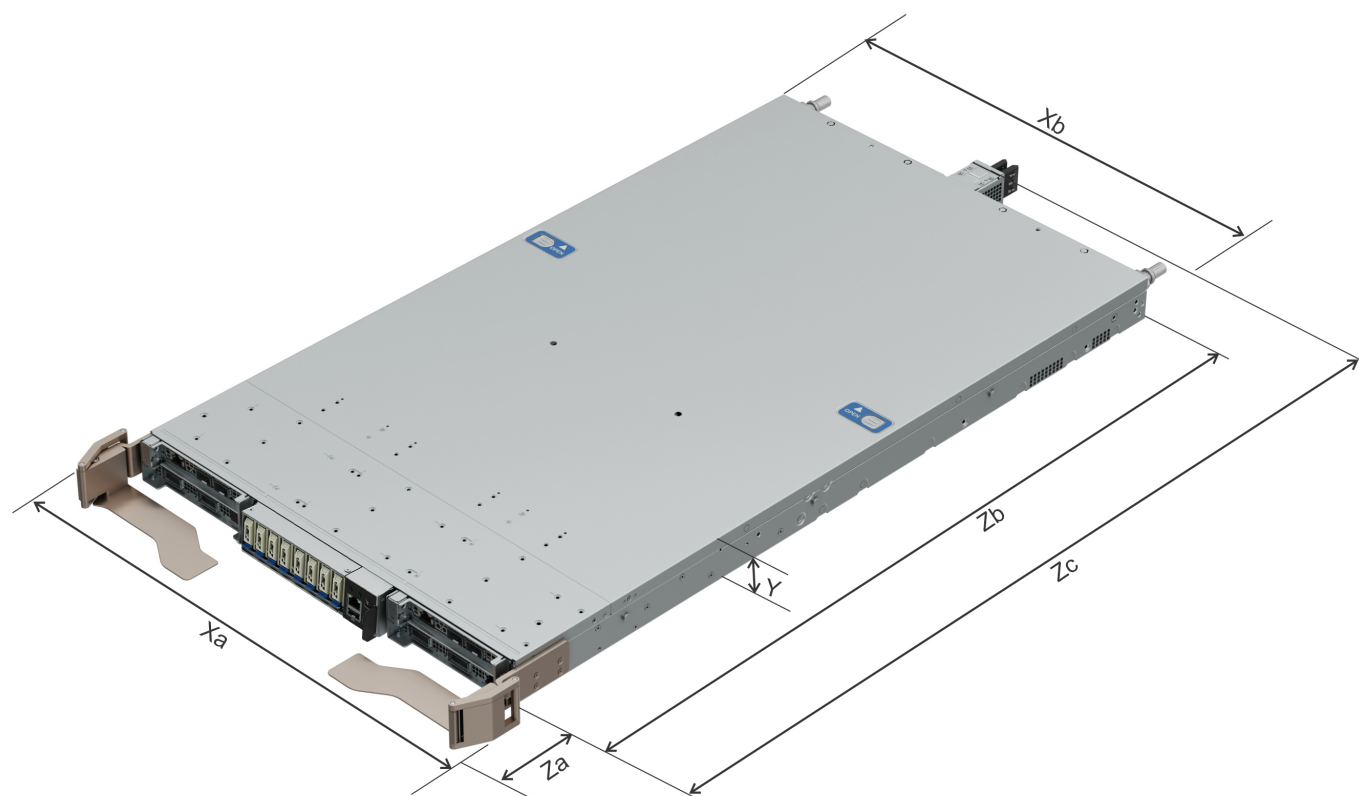



Figure 19. Chassis dimensions

Table 18. PowerEdge XE9712 chassis dimensions

Xa	Xb	Y	Za	Zb	Zc
481.54 mm (18.95 inches)  NOTE: No front bezel	438 mm (17.24 inches)	43.60 mm (1.71 inches)	79.05 mm (3.11 inches)  NOTE: No front bezel	767.08 mm (30.2 inches)	807 mm (31.77 inches)

System weight

Table 19. XE9712 weight

System configuration	Maximum weight
8 x E1.S	30 kg (66.14 pounds)

GPU Specifications

The PowerEdge XE9712 system supports

- Up to four NVLink-C2C: 900GB/s of coherent memory of CPU-GPU interconnection.

NIC port Specifications

The PowerEdge XE9712 system supports

- 1G Network Interface Controller (NIC) Printed circuit board (PCB) installed in front of the sled.

Video specifications

The PowerEdge XE9712 system supports integrated Matrox G200 graphics controller with 16 MB of video frame buffer.

Table 20. Supported video resolution options

Resolution	Refresh rate (Hz)	Color depth (bits)
1024 x 768	60	8, 16, 32
1280 x 800	60	8, 16, 32
1280 x 1024	60	8, 16, 32
1360 x 768	60	8, 16, 32
1440 x 900	60	8, 16, 32
1600 x 900	60	8, 16, 32
1600 x 1200	60	8, 16, 32
1680 x 1050	60	8, 16, 32
1920 x 1080	60	8, 16, 32
1920 x 1200	60	8, 16, 32

Environmental specifications

 **NOTE:** For additional information about environmental certifications, see the Product Environmental Datasheet that are located with the Manuals and Documents on [Dell Support](#).

Table 21. Operational climatic range category A2

Temperature	Specifications
Allowable continuous operations	
Temperature ranges for altitudes <= 900 m (<= 2953 ft)	10–35°C (50–95°F) with no direct sunlight on the equipment
Humidity percent ranges (non-condensing always)	8% RH with -12°C minimum dew point to 80% RH with 21°C (69.8°F) maximum dew point
Operational altitude derating	Maximum temperature is reduced by 1°C/300 m (33.8°F/984 Ft) above 900 m (2953 Ft)

i **NOTE:** Certain system hardware configurations may require operating temperatures to be less than 28°C. For more information, see the Thermal air restrictions section.

Table 22. Shared requirements across all categories

Temperature	Specifications
Allowable continuous operations	
Maximum temperature gradient (applies to both operation and nonoperation)	20°C in an hour* (36°F in an hour) and 5°C in 15 minutes (41°F in 15 minutes), 5°C in an hour* (41°F in an hour) for tape i NOTE: * - Per ASHRAE thermal guidelines for tape hardware, these are not instantaneous rates of temperature change.
Nonoperational temperature limits	-40 (-5)** to 65°C (-40 (23)** to 149°F) i NOTE: ** Liquid filled components, or systems/solutions containing liquid filled components are limited to approximately 5°C above their freeze point. The only authorized liquid coolant is Recochem PG25 with a freeze point between -9°C and -13°C, therefore the lower nonoperational temperature limit is -5°C. Components and systems.solutions that can contain liquid but do not at the time of testing shall be tested to the -40°C lower nonoperational temperature limit.
Nonoperational humidity limits	5% to 95% RH with 27°C (80.6°F) maximum dew point
Maximum nonoperational altitude	12,000 meters (39,370 ft)
Maximum operational altitude	3,048 meters (10,000 ft)

Table 23. Maximum vibration specifications

Maximum vibration	Specifications
Operating	0.1 G _{rms} 5 Hz–100 Hz (x, y, and z axes)
Storage	1.1 G _{rms} 2 Hz–500 Hz for 15 min (all six sides tested)

Table 24. Maximum shock pulse specifications

Maximum shock pulse	Specifications
Operating	18 consecutively performed half sine shock pulses in the positive and negative x, y, and z axes (three pulses on each side of the system) of six G for up to 11 ms.
Storage	Six consecutively performed Trapezoidal Shock pulses in the positive and negative x, y, and z axes (one pulse on each side of the system) of 30 G for up to 11 ms.

Particulate and gaseous contamination specifications

The following table defines the limitations that help avoid any equipment damage or failure from particulates and gaseous contamination. If the levels of particulates or gaseous pollution exceed the specified limitations and result in equipment damage or failure, you must rectify the environmental conditions. Remediation of environmental conditions is the responsibility of the customer.

Table 25. Particulate contamination specifications

Particulate contamination	Specifications
Air filtration	<p>Data center air filtration as defined by ISO Class 8 per ISO 14644-1 with a 95% upper confidence limit.</p> <p>NOTE: The ISO Class 8 condition applies to data center environments only. This air filtration requirement does not apply to IT equipment designed to be used outside a data center, in environments such as an office or factory floor.</p> <p>NOTE: Air entering the data center must have MERV11 or MERV13 filtration</p>
Conductive dust	<p>Air must be free of conductive dust, zinc whiskers, or other conductive particles.</p> <p>NOTE: This condition applies to data center and non-data center environments.</p>
Corrosive dust	<ul style="list-style-type: none"> Air must be free of corrosive dust. Residual dust present in the air must have a deliquescent point less than 60% relative humidity. <p>NOTE: This condition applies to data center and non-data center environments.</p>

Table 26. Gaseous contamination specifications

Gaseous contamination	Specifications
Copper coupon corrosion rate	<300A/month per class G1 as defines by ANSI/ISA71.04-2013
Silver coupon corrosion rate	<200A/month as defined by ANSI/ISA71.04-2013

Appendix B. Standards compliance

The system conforms to the following industry standards.

Table 27. Industry standard documents

Standard	URL for information and specifications
ACPI Advance Configuration and Power Interface Specification, v6.4	ACPI
Ethernet IEEE Std 802.3-2022	IEEE Standards
MSFT WHQL Microsoft Windows Hardware Quality Labs	Windows Hardware Compatibility Program
IPMI Intelligent Platform Management Interface, v2.0	IPMI
DDR5 Memory DDR5 SDRAM Specification	DDR5 SDRAM
PCI Express PCI Express Base Specification, v5.0	PCIe specifications
PMBus Power System Management Protocol Specification, v1.2	PMBus specifications
SMBIOS System Management BIOS Reference Specification, v3.3.0	DMTF SMBIOS
TPM Trusted Platform Module Specification, v2.0	TPM specifications
UEFI Unified Extensible Firmware Interface Specification, v2.7	UEFI specifications
PI Platform Initialization Specification, v1.7	
USB Universal Serial Bus v2.0 and SuperSpeed v3.0 (USB 3.1 Gen1)	USB document library
NVMe Express Base Specification. Revision 2.0c	NVMe specifications
NVMe Command Set Specifications	
1. NVMe Express NVM Command Set Specification. Revision 1.1c	
2. NVMe Express Zoned Namespaces Command Set. Revision 1.0c	
3. NVMe Express® Key Value Command Set. Revision 1.0c	
NVMe Transport Specifications	
1. NVMe Express over PCIe Transport. Revision 1.0c	
2. NVMe Express RDMA Transport Revision. 1.0b	
3. NVMe Express TCP Transport. Revision 1.0c	
NVMe NVM Express Management Interface. Revision 1.2c	
NVMe NVMe Boot Specification. Revision 1.0	

Appendix C: Additional resources

Table 28. Additional resources

Resource	Description of contents	Location
Installation and Service Manual	<p>This manual, available in PDF format, provides the following information:</p> <ul style="list-style-type: none"> • Chassis features • System Setup program • System indicator codes • System BIOS • Remove and replace procedures • Diagnostics • Jumpers and connectors 	Dell.com/Support/Manuals
Getting Started Guide	<p>This guide ships with the system, and is also available in PDF format. This guide provides the following information:</p> <ul style="list-style-type: none"> • Initial setup steps 	Dell.com/Support/Manuals
Rack Installation Guide	<p>This document ships with the rack kits, and provides instructions for installing a server in a rack.</p>	Dell.com/Support/Manuals
System Information Label	<p>The system information label documents the HPM board layout and system jumper settings. Text is minimized due to space limitations and translation considerations. The label size is standardized across platforms.</p>	Inside the system chassis cover
MyDell label	<p>This code on the chassis can be scanned by a phone application to access additional information and resources for the server, including videos, reference materials, service tag information, and Dell contact information.</p>	Inside the system chassis cover
Enterprise Infrastructure Planning Tool (EIPT)	<p>The Dell online EIPT enables easier and more meaningful estimates to help you determine the most efficient configuration possible. Use EIPT to calculate the power consumption of your hardware, power infrastructure, and storage.</p>	Dell.com/calc

Appendix D: Service and support

Topics:

- Why attach service contracts
- ProSupport Infrastructure Suite
- Specialty Support Services
- ProDeploy Infrastructure Suite
- Supplemental Deployment Services
- DAY 2 – Automation Services with Ansible
- Dell Technologies Consulting Services

Why attach service contracts

Dell PowerEdge XE servers include a standard three-year hardware warranty covering repair or replacement of defective components. This warranty reflects the commitment to product quality but is limited to hardware-related issues and does not include software support. For extended warranty coverage and comprehensive support of both hardware and software, choose the ProSupport Infrastructure Suite.

ProSupport Infrastructure Suite

Enterprise-class support that aligns with the criticality of your systems, the complexity of your environment, and how you allocate your IT resources. ProSupport Infrastructure Suite offers three service tiers: Basic Hardware Support, ProSupport for Infrastructure and ProSupport Plus for Infrastructure. These services extend hardware coverage, ensuring continued support beyond the standard warranty period. ProSupport and ProSupport Plus also address common software-related issues, ensuring comprehensive support for both hardware and software. ProSupport Plus offers enhanced capabilities, including support for third-party software, proactive system maintenance, and personalized guidance for performance optimization and other advanced needs. To ensure uninterrupted operation and optimal performance of Dell PowerEdge XE servers, it is recommended to evaluate and select the appropriate ProSupport Infrastructure Suite service based on the specific requirements of your environment.

	Basic Hardware Support	ProSupport	BEST ProSupport Plus
Outcome Assistance and Advocacy via assigned Technical Customer Success Manager ⓘ			
Enjoy a frictionless customer experience with cross-functional lifecycle management aligned to your goals			✓
Accelerate time-to-value through onboarding assistance, education and success planning			✓
Turn challenges into opportunities with actionable strategies powered by data and AI-driven analytics			✓
Ensure coverage continuity while preparing to scale for future success			✓
Proactive Monitoring & Actionable Insights via Dell's connectivity solutions and tools			
Quickly visualize performance through a current system health score		✓	✓
Cybersecurity monitoring and mitigation recommendations provide another layer of protection		✓	✓
Predictive performance and capacity analysis address bottlenecks		✓	✓
Prevent or plan for downtime with predictive hardware anomaly detection		✓	✓
Energy consumption and carbon footprint forecasting support sustainability and stewardship initiatives		✓	✓
Get ahead of problems with proactive issue detection with automated case creation		✓	✓
Streamline internal IT efforts with efficient service request and escalation management tools	✓	✓	✓
Minimize disruptions by self-dispatching eligible parts	✓	✓	✓
Support Essentials			
Receive an assigned incident manager for Sev 1 issues who will work your issue through to resolution		✓	✓
Count on Mission Critical Support during Sev 1 incidents and natural disasters ⓘ			✓
Keep systems code current and performing at peak through Proactive System Maintenance			✓
Get priority access to senior technical support engineers—skip the queues and callbacks			✓
Bringing your own software? We provide limited 3rd party software support ⓘ			✓
Choose onsite parts delivery and labor response that meets your needs	Next Business Day	NBD or 4-hour	4-hour
Select product coverage that best augments your internal resources	Hardware	Hardware & Software	Hardware & Software
Have an issue? We are here for you by phone, chat and online	Local business hours	24/7/365	24/7/365

Figure 20. ProSupport Infrastructure Suite

ProSupport Plus for Infrastructure

ProSupport Plus for Infrastructure is designed for customers who require proactive, predictive, and personalized support for business-critical systems. This service is ideal for environments managing essential applications and workloads where optimal performance and preventative maintenance are paramount. ProSupport Plus is recommended for PowerEdge XE servers to ensure comprehensive, preventative support for business-critical systems.

ProSupport Plus includes 4-hour onsite parts and labor response, all the features of ProSupport, and the following exclusive to ensure maximum uptime and system reliability:

1. **Priority Access to Senior Support Experts:** First in line access to Dell's most experienced support engineers for advanced troubleshooting and issue resolution.
2. **Mission Critical Support:** Rapid response and resolution for Severity 1 issues to minimize downtime and restore operations as quickly as possible.
3. **Technical Customer Success Manager (TCSM):** A dedicated advocate for cross-functional lifecycle management, advocacy, onboarding, and strategic planning throughout your technology journey.
4. **Proactive Systems Maintenance:** Semiannual updates to firmware, BIOS, and drivers to enhance system performance and availability.
5. **Third-Party Software Support:** Dell serves as a single point of accountability for eligible third-party software installed on ProSupport Plus systems, regardless of whether the software was purchased from Dell.

ProSupport for Infrastructure

ProSupport for Infrastructure provides comprehensive 24x7x365 support for hardware and software, ideal for production workloads and applications that are important but not business-critical. ProSupport for Infrastructure is designed to keep your IT environment running smoothly with expert assistance and proactive solutions. This service ensures minimized disruptions and maximized availability of PowerEdge XE server workloads through:

- **24x7x365 Support:** Immediate remote support routing to the next available technician (no waiting for a call back), with 4-hour and Next Business Day onsite parts and labor dispatch options.
- **Broad, Centralized Support:** A single point of contact for hardware and software assistance, covering hypervisors, operating systems, applications, and eligible third-party software purchased from Dell and installed on ProSupport-covered servers.
- **Incident Management:** A dedicated Incident Manager for Severity 1 issues, collaborating with Dell experts and staying engaged until resolution.
- **Enhanced Proactive and Predictive Tools:** AI-driven anomaly detection, automated case creation followed by proactive outreach from Dell support, and infrastructure health/cybersecurity/energy monitoring via Dell AIOps and connectivity platforms.
- **Global Consistency:** A seamless support experience, regardless of location or language.

Basic Hardware Support

Basic Hardware Support provides foundational support for hardware issues, including:

- Access to technical support during local business hours (phone, chat, online).
- Next Business Day (NBD) onsite parts and labor response.
- Hardware troubleshooting only (no software troubleshooting, unless it's to confirm hardware functionality).
- Proactive automated issue detection and automated case creation if the system is connected (customer receives notification and must contact Dell to proceed; unattended queue approach).

Specialty Support Services

Optional specialty support services complement the ProSupport Infrastructure Suite to provide additional expertise that are critical for modern data center operations.

Hardware coverage add-ons to ProSupport or ProSupport Plus

- **Keep Your Hard Drive (KYHD), Keep Your Component (KYC), or Keep Your GPU (KYGPU):**

Normally if a device fails under warranty, Dell replaces it using a one-for-one exchange process. KYHD/KYCC/KYGPU gives you the option to retain your device. It provides full control of sensitive data and minimizes security risk by letting you retain possession of failed drives, components, or GPU when receiving replacement parts without incurring additional cost.

- **Onsite Diagnosis Service:**

Ideal for sites with non-technical staff. A Dell certified field technician performs initial troubleshooting diagnosis onsite and collaborates with remote Dell support engineers to resolve the issue. Customers can request dispatch of an onsite technician at any time for any severity support incident.

- **ProSupport Add-on for HPC (High Performance Computing):**

The ProSupport Add-on for HPC enhances a ProSupport Infrastructure Suite service contract by providing solution-aware support tailored to the unique needs of maintaining an HPC environment. Key features include:

- Access to Senior HPC Experts: Direct support from specialists with deep expertise in HPC systems.
- Advanced HPC Cluster Assistance: Guidance on performance optimization, interoperability, and configuration.
- Enhanced End-to-End Support: Comprehensive solution-level support for HPC environments.
- Remote Pre-Support Engagement: Collaboration with HPC specialists during deployment implementation to ensure a smooth setup process.

- **Carrier-Grade Support:**

Carrier-Grade Support service is designed for leading global telecommunications customers. It offers direct access to Dell solution experts specializing in telecommunications applications and outcomes. This service includes a hardware uptime guarantee, ensuring system restoration within 4 hours for Severity 1 issues. If service-level agreements (SLAs) are not met, Dell assumes penalties and fees, reinforcing its commitment to reliability and performance.

Personalized support and supplemental infrastructure expertise

- **Technical Account Manager (TAM):** The Dell TAM service provides a designated technology expert who monitors and manages the performance and configuration of specific technology sets. TAMs strive to gain deep knowledge of your environment and business goals in order to deliver recommendations for Dell solutions that optimize IT performance and resilience.
- **Designated Support Engineer (DSE):** The Dell DSE service provides an assigned technical expert that delivers personalized, hands-on troubleshooting expertise. Acting as your direct point of contact for all support needs, our DSEs ensure swift problem resolution, real-time communication and tailored recommendations to help you maintain a resilient and efficient IT environment.
- **Multivendor Support Service (MVS):** Support your non-Dell infrastructure devices under one support contract serviced by Dell. An MVS support contract can include coverage for Broadcom, Cisco, Fujitsu, HPE, Hitachi, Huawei, IBM, Lenovo, NetApp, Oracle, Quanta, Supermicro and others.

Services for Large Enterprises

- **ProSupport One for Data Center:**

ProSupport One for Data Center is designed to deliver scalable, efficient, and reliable support for complex IT environments. ProSupport One for Data Center is available for large and distributed data centers with over 1,000 assets (including servers, storage, data protection, and networking devices) or a significant investment in Dell storage and HCI products. Built on the foundation of ProSupport, this support offer is designed for Dell's largest customers, enabling them to customize a support solution that meets their unique hardware and software needs. Key benefits include:

- **Customized Support:** Tailor support services to address unique data center environments and existing IT systems and capabilities.
- **Cost-Effective Options:** Choose support that aligns with technical support consumption and budget, optimizing investments while maintaining required service levels.
- **Resource Augmentation:** Add a Technical Account Manager (TAM) or Designated Support Engineer (DSE) to augment your team. TAMs provide advanced knowledge and advice to help customers realize maximum value from their enterprise investments and the DSE is a designated product-focused troubleshooting expert who understands the environment to enhance overall health.
- **Enhanced Infrastructure Management:** Leverage advanced automation, real-time infrastructure monitoring, and AI-powered analytics to streamline operations, reduce risks, and minimize downtime.

- **Onsite Parts Service (OPS)**

Ideal for large organizations that have their own staff to support their data center, OPS enables Dell and the customer to collaboratively manage parts inventory located at the customer's designated facility. Dell Logistics Online Inventory Solution (LOIS) software program is used to monitor and automate replenishment of inventory in the customer's onsite parts locker. As a replacement part is scanned out of inventory for use, the LOIS software automatically initiates a replenishment order with Dell that is either shipped the next day or delivered onsite by Dell during a scheduled onsite service visit. LOIS also allows customers to integrate their inventory system directly to Dell TechDirect using APIs to further streamline the support and parts management processes.

End-of-Life Services

- **Asset Recovery Services** are available on infrastructure products such as servers, storage and networking assets. The service provides secure disposition, regulatory compliance, value recovery, and environmental reporting—helping customers retire IT infrastructure with confidence while supporting sustainability goals.
- **Data Sanitization & Data Destruction** services render data unrecoverable on repurposed or retired products such as servers, storage and data protection hardware. Data Sanitization is performed according to NIST SP 800-88 r1 guidelines which ensures complete and irreversible removal of sensitive data from devices. When erasure is not feasible, Data Destruction services provide physical destruction of hard drives. All activities are documented, with detailed compliance reports provided for both data sanitization and data destruction outcomes—helping organizations retire infrastructure assets safely and in alignment with regulatory expectations.

ProDeploy Infrastructure Suite

ProDeploy Flex for factory rack integration and cluster services

For small or large opportunities desiring preconfigured servers and/or networking delivered in fully or partially populated racks, our services for AI infrastructure deployment deliver end-to-end, rack-scale deployment and validation for PowerEdge XE platforms paired with options for AI networking. These services include factory rack integration (L11), cluster build (L12), and acceptance testing to ensure Day-1 readiness and peak performance for AI workloads.

- Infrastructure Readiness Assessment to evaluate the data center prior to an AI deployment to include: datacenter layout, power/cooling (including liquid cooling), cabling, airflow, and site logistics.
- Factory rack integration (L11) of advanced PowerEdge XE servers integrated with NVIDIA InfiniBand switches or Ethernet options from Dell or NVIDIA are put through a set of strenuous tests to validate functionality of the solution prior to shipping.
- Rack placement, power connectivity, and liquid-cooling connectivity if applicable.
- Cluster build (L12) turns multiple integrated racks into a high-performance cluster: deploy all inter-rack cabling, configure the AI fabric, validate cluster, and perform acceptance testing.
- Knowledge transfer and project documentation to equip your team for Day-2 operations and ongoing improvements.

ProDeploy Flex for factory rack integration is the most effective method to deploy rack solutions and optimize at scale.

ProDeploy Plus for onsite builds

For smaller quantity solutions that don't require factory rack integration, ProDeploy Plus is ideal. This service provides expert onsite installation and configuration for complex PowerEdge XE platforms. All implementations are performed by Dell-badged employees, not 3rd parties, to ensure the utmost care and expertise is maintained through the entire process.

- Accelerate time to value with Dell engineers, site readiness and implementation planning, full onsite software installation and configuration, and validation prior to handoff.
- Proven speed: up to 3x faster planning and deployment versus in house admins with the ProDeploy Infrastructure Suite.
- Ideal for smaller XE deployments or unique proof-of-concept racks when factory services are not being used; complements rack integration for larger, rack scale AI builds.
- Reduce risk on GPU dense systems with Dell's specialized XE deployment practices and testing rigor built for AI servers.

Supplemental Deployment Services

Additional ways to expand scope or deploy for unique scenarios.

Residency Services

Certified technical professionals act like an extension of your IT staff to enhance internal capabilities and resources and help you realize faster adoption and maximized ROI of new technology. Residency Services help customers transition to new capabilities quickly by leveraging specific technology skill sets. Residency experts can provide post implementation management and knowledge transfer that is related to a new technology acquisition or day-to-day operational management of the IT infrastructure.

- Global experts available to serve in-person (onsite) or virtual (remote).
- Engagements starting at 2 weeks with flexibility to adjust.
- Residency is available for project management needs, and many different technology skills sets such as: AI expertise, compute, storage, networking, security, multi-cloud, data management, and modern workforce applications.

Additional Deployment Time (ADT)

You can expand the scope of a ProDeploy engagement leveraging Additional Deployment Time (ADT). ADT covers additional non-complex tasks beyond the usual quantity of deliverables of the ProDeploy offers. ADT can also be used as a standalone service without ProDeploy, to accomplish tasks related to Project Management or Technical Resource Expertise. ADT is sold in blocks of four hours remote or eight hours onsite. The Dell delivery team can help scope the number of hours required for specific customer needs.

Data Migration Services

Migrating data sets is no easy task. Our experts use proven tools and processes to streamline data migrations and avoid compromising data. A customer project manager works with our experienced team of experts to create a migration plan. Data migration is part of every technology upgrade, platform change, and shift to the cloud. You can rely on Dell data migration services to perform a seamless transition while our customers can keep their focus on their core business.

DAY 2 – Automation Services with Ansible

Dell solutions are built as “automation ready” with integrated APIs (Application Programming Interfaces) to allow customers to programmatically call actions on the product through code. Although Dell has published Ansible automation use cases, some customers need additional assistance with GitOps. By the end of the service, the customer will have the foundational components required to accelerate automation and understand how the programming works together: Day 1 and Day 2 use case automation scripts (ansible modules), CI/CD tool (Jenkins), and Version control (Git).

DAY 2 – Automation Services with Ansible

Dell solutions are built as “automation ready” with integrated APIs (Application Programming Interfaces) to allow customers to programmatically call actions on the product through code. Although Dell has published Ansible automation use cases, some customers need additional assistance with GitOps. By the end of the service, the customer will have the foundational components required to accelerate automation and understand how the programming works together: Day 1 and Day 2 use case automation scripts (ansible modules), CI/CD tool (Jenkins), and Version control (Git).

Dell Technologies Consulting Services

Accelerate Modernization Initiatives with Dell Consulting

When it comes to your IT and business goals, there are a ton of possible initiatives you can focus on and problems you can solve. But it can be confusing and complex when deciding what you should prioritize for your organization and where to start. The experts at Dell Technologies Consulting Services help you harmonize your business and IT needs with our outcome-focused approach. From strategy to full-scale implementation, we can deliver more, faster, so you and your organization can get back to innovating. We listen to and understand your unique needs, then collaborate with you to help you deliver the most value to your business. With decades of expertise and repeatable, proven processes, you get consistent outcomes and accelerated time-to-value. All with a holistic approach to your business outcomes. So whether you're looking to deliver cloud platforms, workforce experiences, data and applications, or achieve a resilient security posture for your business, you can be confident that your organization is heading in the right direction with Dell.

The first step: Half-day workshops.

Identify priorities to build your digital future. Our facilitated workshop discussions focus on the activities required to achieve your desired end state and conclude with next steps to further advance your business and IT strategies.

Available workshops: AI, Multicloud, Apps & Data, Modern Workforce, Security & Resiliency.

Dell Managed Services

Some customers prefer Dell to manage the complexity and risk of daily IT operations, Dell Managed Services utilizes proactive, AI enabled delivery operations and modern automation to help customers realize desired business outcomes from their infrastructure investments. With these technologies, our experts run, update, and fine-tune customer environments that are aligned with service levels, while providing environment-wide and down-to-the-device visibility. There are two types of managed service offers. First the outsourcing model or CAPEX model where Dell manages the customer owned assets using our people and tools. The second is the as-a-Service model or OPEX model called APEX. In this service, Dell owns all technology and all the management of it. Many customers will have a blend of the two management types depending on the goals of the organization.

Cyber-Security Services

Managed Detection and Response (MDR)

Dell Managed Detection and Response Pro Plus is our fully-managed, 360° security operations solution comprised of our most cutting-edge, preventive and responsive cybersecurity services. MDR Pro Plus was designed with your top security concerns in mind, allowing you to focus on your core business goals while Dell handles your security operations. First, we have Vulnerability Management. With this service, we'll do ongoing scanning of the customer's environment looking for software that needs to be patched. Next is Pen Testing and Attack Simulation Management. This service will continuously validate security controls and policies with automated Breach and Attack Simulation (BAS), because a misconfiguration can lead to an exposure which an attacker can exploit. The service also includes an annual penetration test to determine if a skilled threat actor could exploit pathways leading to critical assets or data. Third, Managed Security Awareness Training. This service will educate the customer's end users so that they don't inadvertently put the customer at risk. If you think about our annual compliance training modules, there is always a security module. This is the same type of thing, but rather than once a year, it will be smaller, bite-size pieces of content delivered throughout the year. Fourth is our Managed Detection and Response service which provides 24x7 threat detection and investigation, analysis of end-to-end activity by threat actors, threat hunting, and quick initiation of cyber incident response when needed. Customers can choose between SecureWorks Taegis XDR, CrowdStrike Falcon XDR or Microsoft Defender XDR as the security analytics platform our analysts will use to monitor their environment. All four of these services are delivered by experienced, certified Dell security experts using advanced technology such as the SecureWorks Taegis XDR, CrowdStrike Falcon XDR or Microsoft Defender XDR security platforms.

Dell Technologies Education Services

Build the IT skills required to influence the transformational outcomes of the business. Enable talent and empower teams with the right skills to lead and perform transformational strategy that drives competitive advantage. Leverage the training and certification that is required for real transformation.

Dell Technologies Learning Services offers training and certifications that are designed to help customers achieve more from their hardware investment. To learn more or register for a class today, see learning.dell.com.