

# Dell PowerEdge XE9685L

## Technical Guide

## Notes, cautions, and warnings

 **NOTE:** A NOTE indicates important information that helps you make better use of your product.

 **CAUTION:** A CAUTION indicates either potential damage to hardware or loss of data and tells you how to avoid the problem.

 **WARNING:** A WARNING indicates a potential for property damage, personal injury, or death.

<b>Chapter 1: System overview</b> .....	<b>5</b>
Key workloads.....	5
Messaging.....	5
System features .....	6
<b>Chapter 2: Chassis views and features</b> .....	<b>8</b>
Chassis views.....	8
System configurations - Front view for PowerEdge XE9685L.....	8
System configurations - Rear view for PowerEdge XE9685L.....	10
System configurations - Inside view for PowerEdge XE9685L.....	12
<b>Chapter 3: Processor</b> .....	<b>14</b>
Processor features .....	14
Supported processors.....	14
<b>Chapter 4: Memory subsystem</b> .....	<b>15</b>
Supported memory.....	15
System memory guidelines.....	16
<b>Chapter 5: Storage</b> .....	<b>19</b>
Drives.....	19
Internal storage configuration.....	19
<b>Chapter 6: Networking</b> .....	<b>20</b>
Overview.....	20
Supported OCP cards.....	20
<b>Chapter 7: PCIe subsystem</b> .....	<b>21</b>
Expansion card installation guidelines.....	21
<b>Chapter 8: Power, thermal, and acoustics</b> .....	<b>23</b>
Power.....	23
Power Supply Units.....	24
Thermal.....	25
Thermal design.....	25
PowerEdge XE9685L acoustics.....	25
<b>Chapter 9: Rack, rails, and cable management</b> .....	<b>28</b>
Rails information.....	28
<b>Chapter 10: Operating Systems and Virtualization</b> .....	<b>35</b>
Supported operating systems.....	35

<b>Chapter 11: Dell Systems Management.....</b>	<b>36</b>
Integrated Dell Remote Access Controller (iDRAC).....	36
Systems Management software support matrix.....	37
<b>Chapter 12: Appendix A. Additional specifications.....</b>	<b>38</b>
Chassis dimensions.....	38
System weight.....	39
NIC port specifications.....	39
Video specifications.....	39
USB ports specifications.....	40
PSU rating.....	40
Environmental specifications.....	40
Thermal restriction matrix.....	41
<b>Chapter 13: Appendix B. Standards compliance.....</b>	<b>43</b>
<b>Chapter 14: Appendix C Additional resources.....</b>	<b>44</b>
<b>Chapter 15: Appendix D: Service and support.....</b>	<b>45</b>
Why attach service contracts.....	45
ProSupport Infrastructure Suite .....	45
Specialty Support Services.....	46
ProDeploy Infrastructure Suite.....	48
Supplemental Deployment Services .....	49
Dell Technologies Consulting Services.....	49

# System overview

The PowerEdge XE9685L is Dell's latest 2-socket, AMD based, 4U direct liquid-cooled rack server that is designed to handle AI/ML and HPC workloads.

The system features:

- Two 5<sup>th</sup> Generation AMD EPYC™ 9005 Series processors with up to 192 cores per processor.
- 24 DDR5 DIMM slots.
- 6 x 3000 W AC Titanium PSUs are with support for 3+3 FTR and 5+1 redundancy policies for the system with NVIDIA HGX B200 SXM6 GPUs .
- Six high-performance CPU cooling fans on the top layer and six high-performance GPU cooling fans on the bottom layer of the system.
- Up to 12 PCIe Gen5 slots to support the latest Gen5 PCIe devices and networking, enabling flexible networking design.
- Up to eight U.2 NVMe SSD drives (PSBB direct)
- Eight NVIDIA HGX B200 GPUs containing PCIe Gen5 modules enhancing capabilities for AI, Large Language Model training, fine-tuning, and inferencing, and high-performance computing.

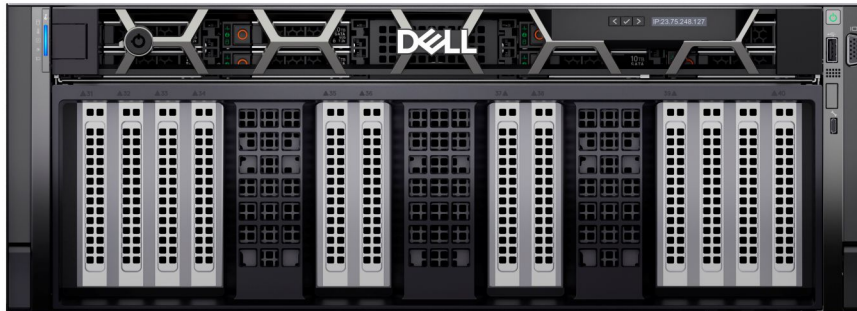

Figure 1. Front view of the 8 x U.2 NVMe SSD drives

## Topics:

- [Key workloads](#)
- [Messaging](#)
- [System features](#)

## Key workloads

The versatile XE9685L is designed to train the most demanding ML/DL large models including:

- Generative AI Training, Fine-Tuning, and large-scale LLM inferencing
- Large natural language processing models, recommendation engines, speech recognition models, conversational AI, chatbots, and digital humans
- AI/ML/DL Training - especially large model training with large datasets
- HPC - Accelerate compute and simulation workloads.

## Messaging

For a comprehensive look at the messaging, refer the internal launch assets pages.

PowerEdge Central link: [PowerEdge .Next - Acceleration Optimized \(sharepoint.com\)](#).

# System features

The following table shows the features of the PowerEdge XE9685L.

**Table 1. Features**

Features	PowerEdge XE9685L
Processors	<ul style="list-style-type: none"> <li>Two 5th Generation AMD EPYC 9005 Series processors with up to 192 cores per processor</li> </ul>
Memory	DIMM Speed <ul style="list-style-type: none"> <li>Up to 6400 MT/s (1 DPC)</li> </ul> Memory Type <ul style="list-style-type: none"> <li>RDIMM</li> </ul> Memory module slots <ul style="list-style-type: none"> <li>24 DDR5 DIMM slots</li> <li>Supports DDR5 registered DIMMs (RDIMMs) slots.</li> </ul> Maximum RAM <ul style="list-style-type: none"> <li>RDIMM 3 TB</li> </ul>
Storage Controllers	<ul style="list-style-type: none"> <li>Internal Boot: Boot Optimized Storage Subsystem (NVMe BOSS-N1): HWRAID 1, 2 x M.2 SSDs</li> </ul>
Drive Bays	Front bays: <ul style="list-style-type: none"> <li>8 x U.2 NVMe direct from PSB</li> </ul>
Power Supplies	<ul style="list-style-type: none"> <li>6 x 3000 W AC Titanium with support for 3+3 FTR and 5+1 redundancy policies</li> </ul>
Cooling Options	<ul style="list-style-type: none"> <li>Direct Liquid Cooling</li> </ul>
Fans	High performance (HPR) Gold fans  Six high-performance cooling fans on the top layer, and six high-performance cooling fans on the bottom layer of the system
Dimension	Height: 174.3 mm (6.86 inches)  Width: Upper 2U: 447 mm (17.59 inches), Lower 2U: 434 mm (17.08 inches)  Depth: 1037.57 mm (40.82 inches) with bezel  1025.62 mm (40.37 inches) without bezel
Form Factor	4U rack server
Embedded Management	<ul style="list-style-type: none"> <li>iDRAC9</li> <li>iDRAC Direct</li> <li>iDRAC RESTful with Redfish</li> <li>iDRAC Service Manual</li> <li>Dell Connectivity Client</li> </ul>
Bezel	Optional LCD bezel or security bezel
OpenManage Software	<ul style="list-style-type: none"> <li>OpenManage Enterprise (OME) APEX AIOps Observability</li> <li>OpenManage Enterprise</li> <li>OpenManage Power Manager plug-in</li> <li>OpenManage Services plug-in</li> <li>OpenManage Update Manager plug-in</li> </ul>
OpenManage Integrations	<ul style="list-style-type: none"> <li>OpenManage Integration with ServiceNow</li> <li>Red Hat Ansible Modules</li> <li>Terraform Providers</li> </ul>
Security	<ul style="list-style-type: none"> <li>Cryptographically signed firmware</li> <li>Data at Rest Encryption (SEDs with local or external key mgmt)</li> </ul>

**Table 1. Features (continued)**

Features	PowerEdge XE9685L	
	<ul style="list-style-type: none"> <li>• Secure Boot</li> <li>• Secured Component Verification (Hardware integrity check)</li> <li>• Secure Erase</li> <li>• Silicon Root of Trust</li> <li>• System Lockdown (requires iDRAC9 Enterprise or Datacenter)</li> <li>• TPM 2.0 FIPS, CC-TCG certified</li> </ul>	
Embedded NIC	2 x 1 GbE LOM	
Networking Options	OCP x8 Mezz 3.0.	
GPU Options	8 x NVIDIA HGX B200 180GB 1000W SXM6 GPUs, fully interconnected with NVIDIA NVLink technology	
Ports	Front Ports <ul style="list-style-type: none"> <li>• 1 x USB 2.0</li> <li>• 1 x iDRAC Direct (Micro-AB USB) port</li> <li>• 1 x VGA</li> </ul>	Rear Ports <ul style="list-style-type: none"> <li>• 1 x USB 2.0</li> <li>• 1 x iDRAC Direct Ethernet port</li> <li>• 1 x USB 3.0</li> </ul>
PCIe	12 Gen5 PCIe slots <ul style="list-style-type: none"> <li>• 10 x16 Gen5 (x16 PCIe) Full-height, Half-length</li> <li>• 2 x16 Gen5 (x16 PCIe) Full-height, Half-length for NIC/SmartNIC/DPU</li> </ul>	
Operating System and Hypervisors	<ul style="list-style-type: none"> <li>• Canonical Ubuntu Server LTS</li> </ul> For specifications and interoperability details, see <a href="#">Dell Enterprise Operating Systems</a> on <a href="#">Servers, Storage, and Networking</a> page at <a href="https://Dell.com/OSsupport">Dell.com/OSsupport</a> .	

## Chassis views and features

### Topics:

- Chassis views

## Chassis views

### System configurations - Front view for PowerEdge XE9685L

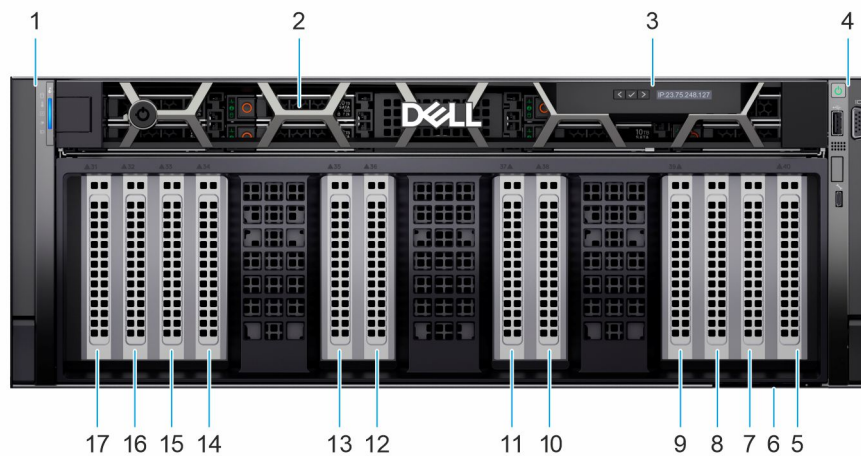

Figure 2. Front view of 8 x U.2 SSD drive system

Table 2. Features available on the front of the 8 x U.2 NVMe SSD drives system

Item	Ports, panels, and slots	Icon	Description
1	Left control panel	N/A	Contains the system health, system ID, and the status LED indicator.
2	Drives	N/A	Enables you to install drives that are supported on your system.
3	LCD panel	N/A	The LCD panel of your system provides system information, status, and error messages to indicate if the system is functioning correctly or if the system needs attention.
4	Right control panel	N/A	Contains the power button, USB port, iDRAC Direct (Micro-AB USB) port.
5	PCIe (slot 42)	N/A	The expansion card riser enables you to connect PCI Express expansion cards. For more information, see the Expansion card installation guidelines section.
6	Express Service Tag	N/A	The Express Service Tag is a slide-out label panel that contains system information such as Service Tag, NIC, MAC address, and so on. If you have opted for the secure default access to iDRAC, the Information tag will also contain the iDRAC secure default password.

**Table 2. Features available on the front of the 8 x U.2 NVMe SSD drives system (continued)**

<b>Item</b>	<b>Ports, panels, and slots</b>	<b>Icon</b>	<b>Description</b>
7	PCIe (slot 41)	N/A	The expansion card riser enables you to connect PCI Express expansion cards. For more information , see the Expansion card installation guidelines section.
8	PCIe (slot 40)	N/A	The expansion card riser enables you to connect PCI Express expansion cards. For more information , see the Expansion card installation guidelines section.
9	PCIe (slot 39 )	N/A	The expansion card riser enables you to connect PCI Express expansion cards. For more information , see the Expansion card installation guidelines section.
10	PCIe (slot 38)	N/A	The expansion card riser enables you to connect PCI Express expansion cards. For more information , see the Expansion card installation guidelines section.
11	PCIe (slot 37)	N/A	The expansion card riser enables you to connect PCI Express expansion cards. For more information , see the Expansion card installation guidelines section.
12	PCIe (slot 36)	N/A	The expansion card riser enables you to connect PCI Express expansion cards. For more information , see the Expansion card installation guidelines section.
13	PCIe (slot 35)	N/A	The expansion card riser enables you to connect PCI Express expansion cards. For more information , see the Expansion card installation guidelines section.
14	PCIe (slot 34)	N/A	The expansion card riser enables you to connect PCI Express expansion cards. For more information , see the Expansion card installation guidelines section.
15	PCIe (slot 33 )	N/A	The expansion card riser enables you to connect PCI Express expansion cards. For more information , see the Expansion card installation guidelines section.
16	PCIe (slot 32)	N/A	The expansion card riser enables you to connect PCI Express expansion cards. For more information , see the Expansion card installation guidelines section.
17	PCIe (slot 31)	N/A	The expansion card riser enables you to connect PCI Express expansion cards. For more information , see the Expansion card installation guidelines section.

## System configurations - Rear view for PowerEdge XE9685L

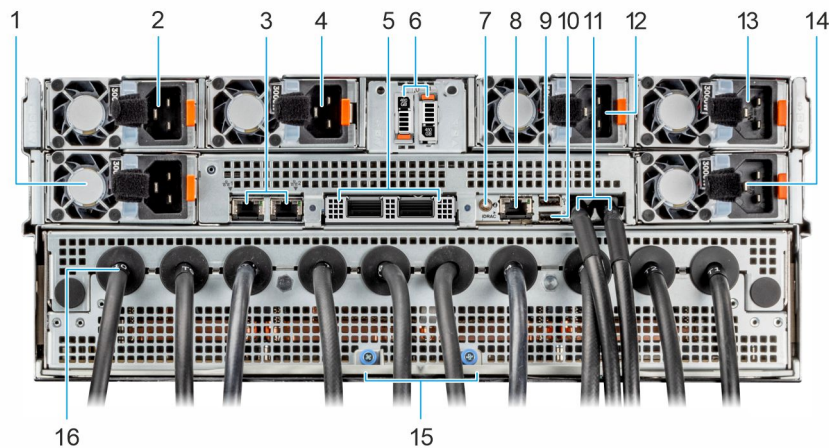





Figure 3. Rear view of the system

Table 3. Rear view of the system

Item	Ports, panels, or slots	Icon	Description
1	Power supply unit (PSU) 2		PSU2 of the system
2	Power supply unit (PSU) 1		PSU1 of the system
3	NIC Ports		The NIC ports are embedded on the LOM card that is connected to the system board.
4	Power supply unit (PSU) 3		PSU3 of the system
5	OCP NIC Card	N/A	The OCP NIC card supports OCP 3.0. The NIC ports are integrated on the OCP card which is connected to the system board.
6	BOSS-N1	N/A	There are two M.2 connectors that are populated on the board and support two NVMe drives for boot.
7	System Identification (ID) button		<p>The System Identification (ID) button is available on the front and back of the system. Press the button to identify a system in a rack by turning on the system ID button. You can also use the system ID button to reset iDRAC and to access the BIOS using the step-through mode. When pressed, the system ID LED in the back panel blinks until either the front or rear button is pressed again. Press the button to switch between on or off mode.</p> <p><b>NOTE:</b> If the server stops responding during POST, press and hold the <b>System ID</b> button for more than five seconds to enter the BIOS progress mode.</p> <p><b>NOTE:</b> To reset the iDRAC (if not disabled on the iDRAC setup page by pressing F2 during system boot), press and hold the <b>System ID</b> button for more than 15 seconds.</p>
8	Dedicated iDRAC9 Ethernet port		Enables you to remotely access iDRAC. For more information, see the <i>Integrated Dell Remote Access Controller User's Guide</i> at <a href="#">PowerEdge Manuals</a>
9	USB 2.0 port		The USB port is 4-pin, 2.0-compliant. This port enables you to connect USB devices to the system.
10	USB 3.0 port		The USB port is 9-pin and 3.0-compliant. This port enables you to connect USB devices to the system.

**Table 3. Rear view of the system (continued)**

<b>Item</b>	<b>Ports, panels, or slots</b>	<b>Icon</b>	<b>Description</b>
11	Direct Liquid Cooling tubes from the processors	N/A	Cold coolant flows into the system from one tube and hot coolant leaves the system from another tube.
12	Power supply unit (PSU) 4	 4	PSU4 of the system
13	Power supply unit (PSU) 5	 5	PSU5 of the system
14	Power supply unit (PSU) 6	 6	PSU6 of the system
15	Rear sled handle	N/A	The rear sled handle is used to slide out the bottom layer of the system.
16	Direct Liquid Cooling tubes from the GPUs	N/A	Cold coolant flows into the system from one tube and hot coolant leaves the system from another tube.

# System configurations - Inside view for PowerEdge XE9685L

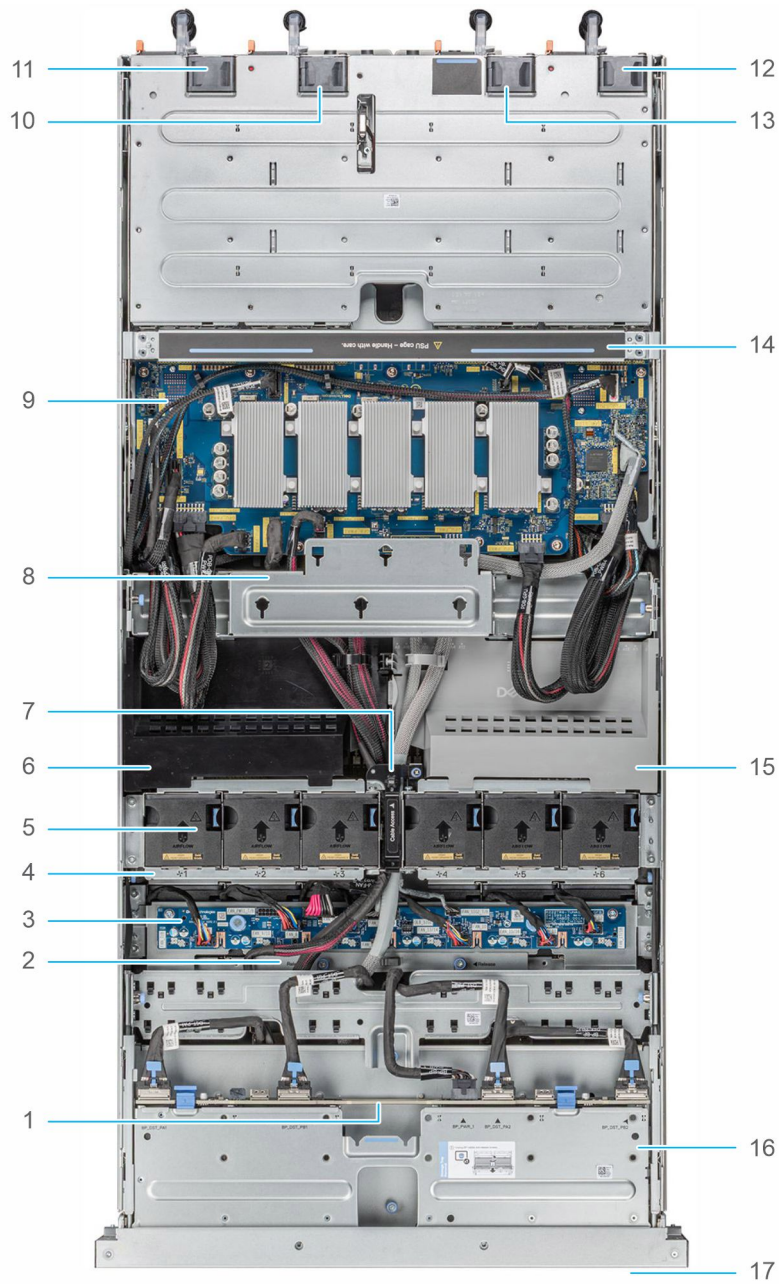

**Figure 4. Inside view of the PowerEdge XE9685L**

- |                                   |  |
|-----------------------------------|--|
| 1. Backplane                      | 2. Bottom layer of the system              |
| 3. GPU Fan board                  | 4. CPU Fan cage                            |
| 5. CPU Fans                       | 6. System board Air baffle                 |
| 7. Cable clip                     | 8. Rear Support bracket                    |
|                                   | <b>i</b> <b>NOTE:</b> The design may vary. |
| 9. Power Distribution Board (PDB) | 10. Power Supply Unit 4 (PSU 4)            |
| 11. Power Supply Unit 5 (PSU 5)   | 12. Power Supply Unit 1 (PSU 1)            |
| 13. Power Supply Unit 3 (PSU 3)   | 14. PDB Cage handle                        |
| 15. System board Air baffle       | 16. Drive cage                             |
| 17. Express Service Tag           |  |

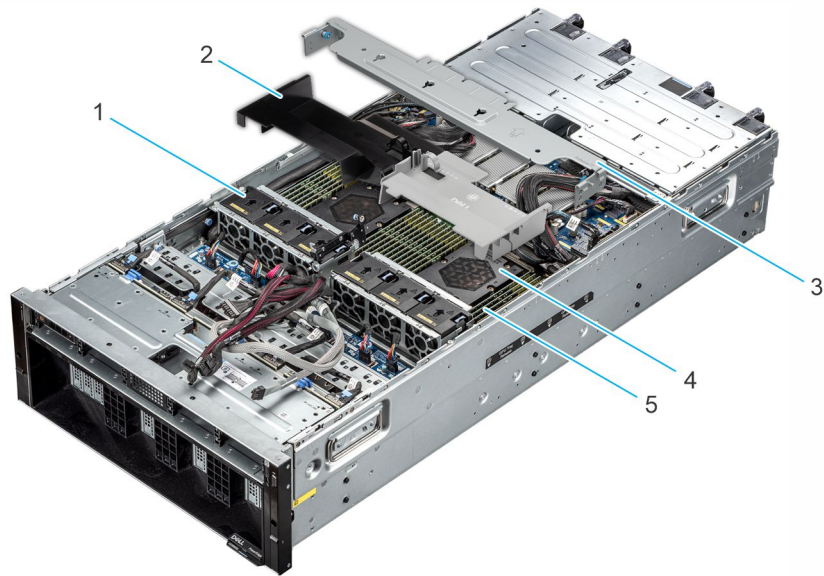

**Figure 5. Inside view of the PowerEdge XE9685L**

- |                     |               |
|---------------------|---------------|
| 1. CPU cooling fans | 2. Air shroud |
| 3. Support bracket  | 4. Processor  |
| 5. Memory module    |               |

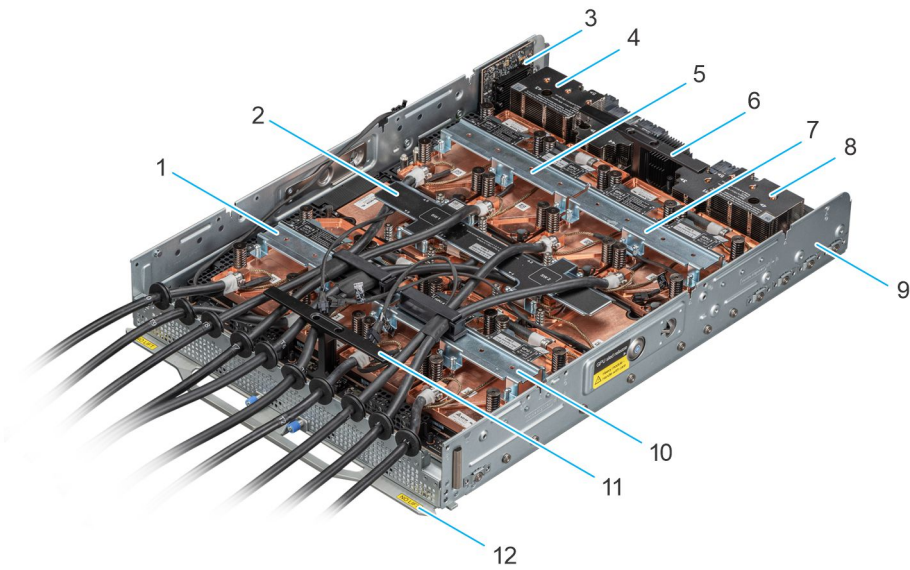

**Figure 6. Inside view of the B200 GPU sled of the PowerEdge XE9685L**

1. Loop 1: GPU with Cold plates
2. Loop 3: NVLink Switches (NVS) cold plate
3. CX-7 module on GPU
4. Retimer heat sink
5. Loop 4: GPU with Cold plates
6. GPU board holder
7. Loop 5: GPU with Cold plates
8. Retimer heat sink
9. B200 GPU sled chassis
10. Loop 2: GPU with Cold plates
11. GPU board holder
12. GPU sled handle

# Processor



## Topics:

- [Processor features](#)

## Processor features

The 5<sup>th</sup> Generation AMD Turin (Zen5/Zen5c) processors stack is the next-generation data center processor offering improved performance, standard increased memory speeds, expanded xGMI speeds and enhanced security.

The following lists the features and functions that are in the 5<sup>th</sup> Generation AMD Turin (Zen5/Zen5c) processors offering:

- Increased core counts with up to 192 cores
- Enhanced memory performance with DDR5 and memory speed up to 6400 MT/s at 1 DIMM(s) per CPU (1DPC) and 24 DIMMs in total.
- More, faster I/O with PCI Express 5 and up to 128 lanes (per socket)
- AMD Zen5/Zen5c "TURIN" SP5 socket

## Supported processors

The following table shows the 5<sup>th</sup> Generation AMD servers SKUs that are supported on the PowerEdge XE9685L .

**Table 4. 5th Generation AMD servers: PowerEdge XE9685L**

Model Name	Base Frequency (GHz)	Max Boost Frequency (GHz)	Cores	Threads	Default TDP (W)	cTDP (W)	L3 Cache (MB)	Max DDR Freq (MT/s)
9965	2.25	3.7	192	384	500	450-500	384	6400
9755	2.7	4.1	128	256	500	450-500	512	6400
9655	2.6	4.5	96	192	400	320-400	384	6400
9575F	3.3	5.0	64	128	400	320-400	256	6400
9455	3.15	4.4	48	96	300	240-300	256	6400

# Memory subsystem

## Topics:

- [Supported memory](#)
- [System memory guidelines](#)

## Supported memory

The PowerEdge XE9685L system supports 24 DIMMs (12 per socket), with up to 3 TB of memory and speeds of up to 6400 MT/s.

The PowerEdge XE9685L system supports registered (RDIMMs) which use a buffer to reduce memory loading and provide greater density, allowing for the maximum platform memory capacity. Unbuffered DIMMs (UDIMMs) are not supported.

**Table 5. Memory technology comparison**

Feature	PowerEdge XE9685L (DDR5)
DIMM type	RDIMM
Transfer speed	Supports 1 DPC and up to 6400 MT/s.  <b>NOTE:</b> Maximum DIMM transfer speed support dependent on CPU SKU and DIMM population
Voltage	1.1 V

 **NOTE:** Maximum DIMM transfer speed support dependent on CPU SKU and DIMM population.

The following table lists the supported DIMMs for the PowerEdge XE9685L.

**Table 6. Supported DIMMs**

DIMM Speed (MT/s)	DIMM Type	DIMM Capacity (GB)	Ranks per DIMM	Data Width	DIMM Volts (V)
6400	RDIMM	64	2	x4	1.1
6400	RDIMM	96	2	x4	1.1
6400	RDIMM	128	2	x4	1.1

 **NOTE:** The processor may reduce the performance of the rated DIMM speed.

**Table 7. Minimum system memory requirements**

8xGPU	B200 GPU
<b>Memory</b>	<b>24 pcs</b>
64	Supported
96	Supported
128	Supported

**Table 8. Total System Memory Capacity Requirement**

<b>DIMM capacity</b>	<b>64 GB</b>	<b>96 GB</b>	<b>128 GB</b>
24 x DIMM sockets population	Total memory: 1.5 TB	Total memory: 2.3 TB	Total memory: 3 TB

## System memory guidelines

The PowerEdge XE9685L system supports DDR5 registered DIMMs (RDIMMs). System memory holds the instructions that are started by the processor.

Your system memory is organized into 12 channels per processor (one memory sockets per channel), 12 memory sockets per processor and 24 memory sockets per system.

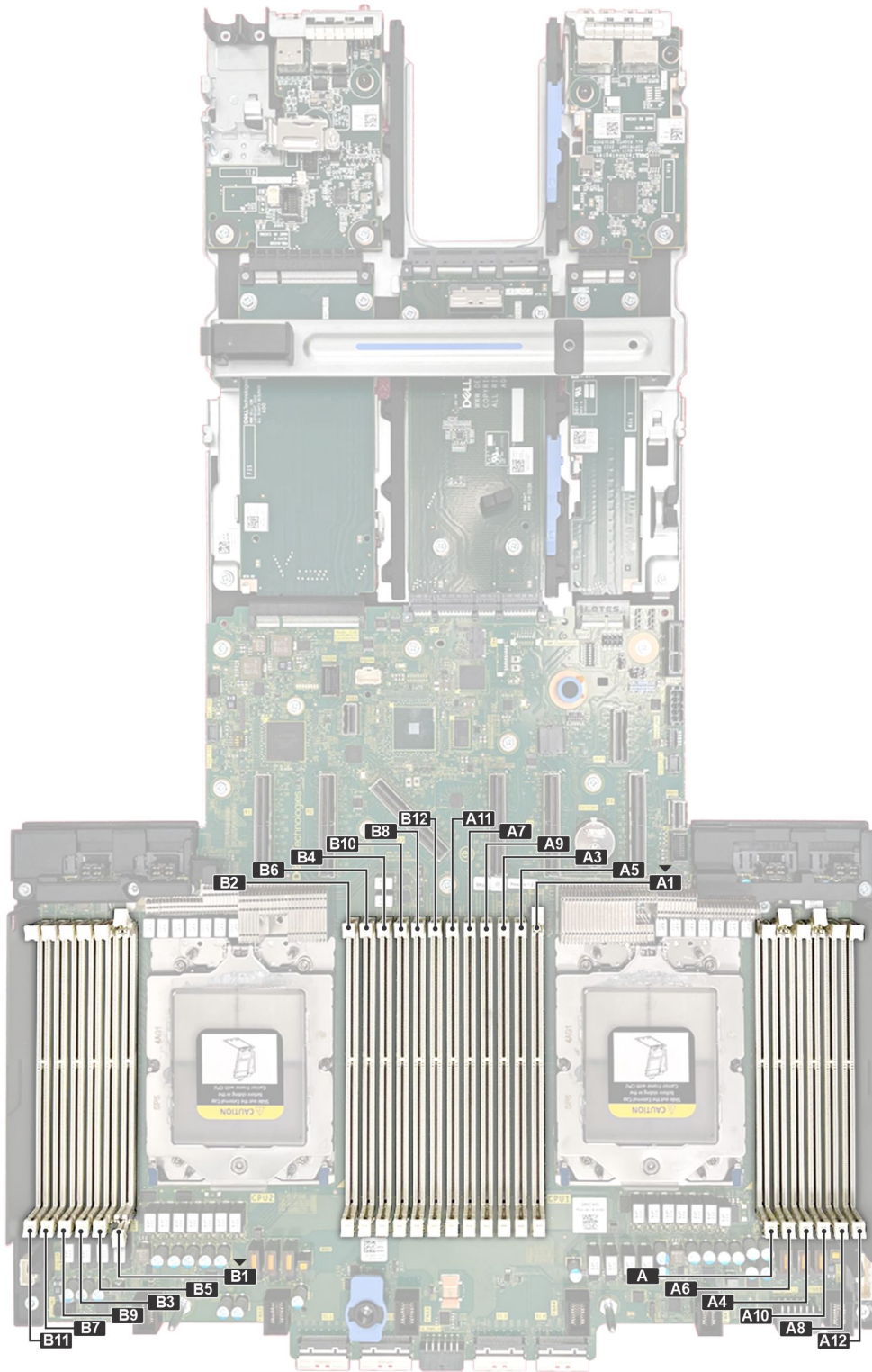

**Figure 7. Memory channels**

Memory channels are organized as follows:

**Table 9. Memory channels A through F**

Processor	Channel A	Channel B	Channel C	Channel D	Channel E	Channel F
Processor 0	Slots A1	Slots A5	Slots A3	Slots A9	Slots A7	Slots A11
Processor 1	Slots B1	Slots B5	Slots B3	Slots B9	Slots B7	Slots B11

**Table 10. Memory channels G through L**

Processor	Channel G	Channel H	Channel I	Channel J	Channel K	Channel L
Processor 0	Slots A2	Slots A6	Slots A4	Slots A10	Slots A8	Slots A12
Processor 1	Slots B2	Slots B6	Slots B4	Slots B10	Slots B8	Slots B12

**Table 11. Supported memory matrix**

DIMM type	Rank	Capacity	DIMM rated voltage and speed	Operating Speed
				1 DIMM per channel (DPC)
RDIMM	2 R	64 GB	DDR5 (1.1 V), 6400 MT/s	Up to 6400 MT/s
		96 GB	DDR5 (1.1 V), 6400 MT/s	
		128 GB	DDR5 (1.1 V), 6400 MT/s	

**NOTE:** The processor may reduce the performance of the rated DIMM speed.

**NOTE:** Maximum DIMM transfer speed support dependent on CPU SKU and DIMM population.

# Storage

## Topics:

- [Drives](#)
- [Internal storage configuration](#)

## Drives

The PowerEdge XE9685L supports:

- 8 x 2.5-inch hot-swappable NVMe SSD drives

## Internal storage configuration

**Table 12. Internal Storage Configuration Matrix**

Supported Options	Total HDD/SSD (not BOSS)	NVMe	1st Front Storage	2nd Front Storage	3rd Front Storage	Rear Storage	PERC Qty	Storage Controller (s)	CPU Qty
C02	8	8 / 0	8 x 2.5-inch NVMe direct attached	N/A	N/A	N/A	0	N/A	2 CPU

# Networking

## Topics:

- [Overview](#)

## Overview

PowerEdge offers a wide variety of options to get information moving to and from our servers. Industry best technologies are chosen, and systems management features are added by our partners to firmware to tie in with iDRAC. These adapters are rigorously validated for worry-free, fully supported use in Dell servers.

## Supported OCP cards

### OCP Cards

**Table 13. Supported OCP cards**

Form factor	Vendor	Port type	Port speed	Port count
OCP 3.0	Broadcom	SFP28	25 GbE	2
	Mellanox	SFP28	25 GbE	2

# PCIe subsystem

## Topics:

- [Expansion card installation guidelines](#)

## Expansion card installation guidelines

The PowerEdge XE9685L system supports up to 12 PCIe Gen5 slots to support the latest Gen5 PCIe devices and networking, enabling flexible networking design.

**Table 14. PCIe Riser Configurations**

Config No.	Riser configuration	No. of Processors	PERC type supported	Rear storage possible
1	RS1+RS2+RS3+RS4	2	Without Front PERC	No

**Table 15. Expansion card slots**

PCIe SW	PCIe slot	Processor Connection	PCIe slot height	PCIe slot length	PCIe slot width
PCIe SW4	31	Processor 2	Full height	Half length	x16
	32	Processor 2	Full height	Half length	x16
	33	Processor 2	Full height	Half length	x16
PCIe SW3	34	Processor 2	Full height	Half length	x16
	35	Processor 2	Full height	Half length	x16
	36	Processor 2	Full height	Half length	x16
PCIe SW2	37	Processor 1	Full height	Half length	x16
	38	Processor 1	Full height	Half length	x16
	39	Processor 1	Full height	Half length	x16
PCIe SW1	40	Processor 1	Full height	Half length	x16
	41	Processor 1	Full height	Half length	x16
	42	Processor 1	Full height	Half length	x16

**Table 16. NIC/Smart NIC/DPU slots**

PCIe slot	Processor Connection	PCIe slot height	PCIe slot length	PCIe slot width
33	Processor 2	Full height	Half length	x16
39	Processor 1	Full height	Half length	x16

**NOTE:** DPUs with high power consumption (> 75W) should be installed in slots 33 and 39. NICs/SmartNICs with normal power consumption (< 75W) can be installed in any slot 31-42.

**Table 17. Configuration 1: RS1+RS2+RS3+RS4**

<b>Card type</b>	<b>Slot priority</b>	<b>Maximum number of cards</b>
Mellanox (DPU: FH, 200G)	33, 39	2
Mellanox (InfiniBand/Ethernet: N400, 1P).	31,37,34, 40, 32, 38, 35, 41, 36, 42, 33, 39	12
Broadcom (FH, 200G, 2P)	31,37,34, 40, 32, 38, 35, 41, 36, 42, 33, 39	12
Mellanox (DPU: FH, 400G)	31,37,34, 40, 32, 38, 35, 41, 36, 42, 33, 39	12
Mellanox (FH, 100G, 2P)	31,37,34, 40, 32, 38, 35, 41, 36, 42, 33, 39	12
NVIDIA (GPGPU B200, 8-GPU SXM6 BB)	21, 22, 23, 24, 25, 26, 27, 28	8
FOXCONN (BOSS-N1)	Integrated Slot	1
LOM Card (1G)	Integrated Slot	1
Mellanox (OCP: 25G, 2P)	Integrated Slot	1
Broadcom (OCP: 25G, 2P)	Integrated Slot	1
Intel (OCP: 10G, 4P)	Integrated Slot	1

For add-in cards that can be mapped to the XE9685L and guidelines for installing expansion cards, see the XE9685L slot priority matrix file on Sales Portal.

Link: [Sales portal](#)

# Power, thermal, and acoustics

PowerEdge servers have an extensive collection of sensors that automatically track thermal activity, which helps regulate temperature thereby reducing server noise and power consumption. The table below lists the tools and technologies Dell offers to lower power consumption and increase energy efficiency.

## Topics:

- [Power](#)
- [Thermal](#)
- [PowerEdge XE9685L acoustics](#)

## Power

**Table 18. Power tools and technologies**

Feature	Description
Power Supply Units(PSU) portfolio	Dell's PSU portfolio includes intelligent features such as dynamically optimizing efficiency while maintaining availability and redundancy. Find additional information in the Power supply units section.
PSU redundancy options	<ul style="list-style-type: none"> <li>• Not Redundant (5+1) FR (System can get full performance)</li> <li>• PSU Redundant (3+3) FTR (System may throttle when more than one PSU is down)</li> </ul>
Tools for right sizing	Enterprise Infrastructure Planning Tool (EIPT) is a tool that can help you determine the most efficient configuration possible. With Dell's EIPT, you can calculate the power consumption of your hardware, power infrastructure, and storage at a given workload. Learn more at <a href="#">Enterprise Infrastructure Planning Tool</a> .
Industry Compliance	Dell's servers are compliant with all relevant industry certifications and guide lines, including 80 PLUS.
Power monitoring accuracy	PSU power monitoring improvements include: <ul style="list-style-type: none"> <li>• Dell's power monitoring accuracy is currently 1%, whereas the industry standard is 5%</li> <li>• More accurate reporting of power</li> <li>• Better performance under a power cap</li> </ul>
Power capping	Use Dell's systems management to set the power cap limit for your systems to limit the output of a PSU and reduce system power consumption.
Systems Management	iDRAC Enterprise and Datacenter provides server-level management that monitors, reports and controls power consumption at the processor, memory and system level.  Dell OpenManage Power Center delivers group power management at the rack, row, and data center level for servers, power distribution units, and uninterruptible power supplies.
Active power management	Dell OpenManage Power Center delivers group power management at the rack, row, and data center level for servers, power distribution units, and uninterruptible power supplies.
Fresh Air cooling	Refer to ASHRAE A3/A4 Thermal Restriction.
Rack infrastructure	Dell offers some of the industry's highest-efficiency power infrastructure solutions, including: <ul style="list-style-type: none"> <li>• <a href="#">Power distribution units</a> (PDUs)</li> <li>• <a href="#">Uninterruptible power supplies</a> (UPSs)</li> <li>• <a href="#">Energy Smart containment rack enclosures</a></li> </ul>

**Table 18. Power tools and technologies (continued)**

Feature	Description
	Find additional information at: <a href="#">Power and Cooling</a> .

The power cap policy setting in iDRAC configuration page controls CPU related power consumption. In XE9685L systems, most of the power is consumed by GPU which cannot be controlled by this setting. Enabling power cap feature will drive CPU to run at very low or lowest frequency speed.

**NOTE:** As of version 7.00.60.00 and later, power cap function is not available.

## Power Supply Units

Energy Smart power supplies have intelligent features, such as the ability to dynamically optimize efficiency while maintaining availability and redundancy. Also featured are enhanced power-consumption reduction technologies, such as high-efficiency power conversion and advanced thermal-management techniques, and embedded power-management features, including high-accuracy power monitoring. The table below shows the power supply unit options that are available for the XE9685L.

**Table 19. PSU specifications for the PowerEdge XE9685L system**

PSU	Power Rating	Class	Heat dissipation (maximum)	Frequency	Voltage	Current
3000 W Mixed Mode (post-RTS)	3000 W	Titanium	10,900 BTU/hr	50/60 Hz	209.1 - 240 V AC	16 A
		N/A	11,000 BTU/hr	N/A	240 V DC	14.6 A
	2800 W	N/A	10,500 BTU/hr	50/60 Hz	200 V AC–209 V AC	16 A

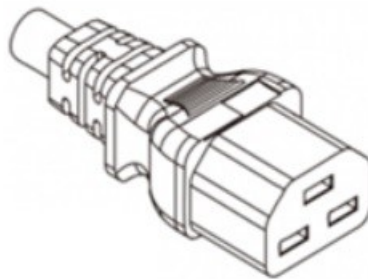

**Power Cord C21**

**Figure 8. PSU power cord**

**Table 20. PSU power cord**

Form factor	Output	Power cord
Redundant 86 mm	3000 W VDC	C21

**NOTE:** Do not mix PSUs from different vendors within a single system configuration to ensure optimal performance and reliability.

# Thermal

PowerEdge servers have an extensive collection of sensors that automatically track thermal activity, which helps regulate temperature thereby reducing server noise and power consumption.

## Thermal design

Thermal management of the platform helps deliver high performance with the right amount of cooling to components, while maintaining the lowest fan speeds possible. This is done across a wide range of ambient temperatures from 10°C to 35°C (50°F to 95°F) and to extended ambient temperature ranges.

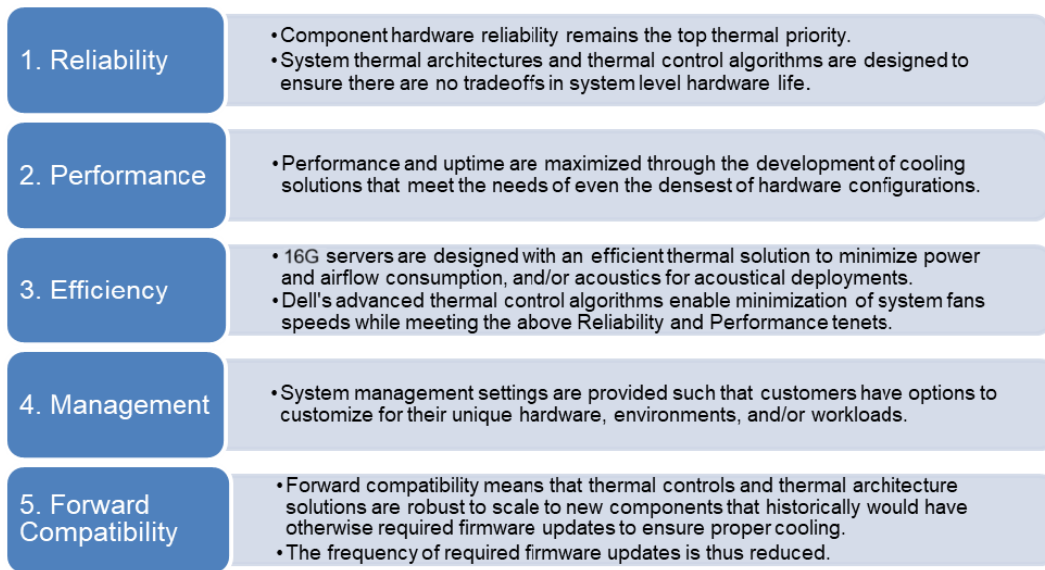

**Figure 9. Thermal design characteristics**

The thermal design of the PowerEdge XE9685L reflects the following:

- Optimized thermal design: The system layout is architected for optimum thermal design.
- System component placement and layout are designed to provide maximum airflow coverage to critical components with minimum expense of fan power.
- Comprehensive thermal management: The thermal control system regulates the fan speed based on several different responses from all system-component temperature sensors, as well as inventory for system configurations. Temperature monitoring includes components such as processors, DIMMs, chipset, the inlet air ambient, hard disk drives, and OCP.
- Open and closed loop thermal fan speed control: Open loop thermal control uses system configuration to determine fan speed based on inlet air ambient temperature. Closed loop thermal control method uses feedback temperatures to dynamically determine proper fan speeds.
- User-configurable settings: With the understanding and realization that every customer has unique set of circumstances or expectations from the system, in this generation of servers, we have introduced limited user-configurable settings residing in the iDRAC BIOS setup screen. For more information, see the Dell PowerEdge XE9685L Installation and Service Manual at [PowerEdge Manuals](#) and “[Advanced Thermal Control: Optimizing across Environments and Power Goals](#)” on Dell.com.
- Cooling redundancy: The PowerEdge XE9685L allows N+1 fan redundancy, allowing continuous operation with one rotor failure in the system.
- Environmental Specifications: The optimized thermal management makes the PowerEdge XE9685L reliable under a wide range of operating environments.

## PowerEdge XE9685L acoustics

Acoustical performances of the typical configurations of XE9685L are listed in the tables below. The acoustical numbers that are listed in the table are test results with a single unit of XE9685L only, not including the sound contributed by CDUs.

**Table 21. Acoustical configurations of PowerEdge XE9685L**

Configuration	NVIDIA B200 GPU (U.2 drive configuration)
Fan Type	12 x High-Performance Gold (6056)
CPU TDP	2 x AMD server with 500 W
RDIMM Memory	24 x 128 GB DDR5
Backplane Type	1 x 8 U.2 BP
HDD/SSD Type	8 x U.2 SSD
PERC	None
BOSS	16G BOSS
BOSS M.2	Micron 480 GB
OCP	25G OCP NIC
PSU Type	6 x 3000 W
Bezel	Yes
GPU	NVIDIA HGX B200 8-GPU
PCI	10 x 400G NIC
DPU	2 x 200G DPU

**Table 22. Acoustical experience of PowerEdge XE9685L configurations**

Configuration	GPU NVIDIA B200 (U.2)	
Acoustical Performance: Idle/ Operating @ 25°C Ambient.		
L <sub>wA,m</sub> <sup>(1)</sup> (B)	Idle <sup>(4)</sup>	6.8
	Operating <sup>(5)</sup> , Customer Usage Operating <sup>(6)</sup>	7.6
K <sub>v</sub> (B)	Idle <sup>(4)</sup>	0.4
	Operating <sup>(5)</sup> , Customer Usage Operating <sup>(6)</sup>	0.4
L <sub>pA,m</sub> <sup>(2)</sup> (dBA)	Idle <sup>(4)</sup>	53
	Operating <sup>(5)</sup> , Customer Usage Operating <sup>(6)</sup>	63
Prominent discrete tones <sup>(3)</sup>		Not noticeable
Acoustical Performance: Idle/ Operating @ 28°C Ambient.		
L <sub>wA,m</sub> <sup>(1)</sup> (B)		7.2
K <sub>v</sub> (B)		0.4
L <sub>pA,m</sub> <sup>(2)</sup> (dBA)		56
Acoustical Performance: Idle/ Operating @ 35°C Ambient.		
L <sub>wA,m</sub> <sup>(1)</sup> (B)		9.5
K <sub>v</sub> (B)		0.4
L <sub>pA,m</sub> <sup>(2)</sup> (dBA)		78

- L<sub>wA,m</sub>: The declared mean A-weighted sound power level (L<sub>wA</sub>) is calculated per section 5.2 of ISO 9296 with data collected using the methods that are described in ISO 7779. Data presented here may not be fully compliant with ISO 7779.

- $L_{pA,m}$ : The declared mean that the A-weighted emission sound pressure level is at the bystander position per section 5.3 of ISO 9296 and measured using methods that are described in ISO 7779. The system is placed in a 24U rack enclosure, 25 cm above a reflective floor. Engineering data presented here may not be fully compliant with ISO 7779 declaration requirements.
- **Prominent discrete tones:** Criteria of Annex D of ECMA-74 and Prominence Ratio method of ECMA-418 are followed to determine if discrete tones are prominent and to report them, if so.
- **Idle mode:** The steady-state condition in which the server is energized but not operating any intended function.
- **Operating mode:** Operating mode is represented by the maximum of the steady state acoustical output at 50% of CPU TDP or active storage drives for the respective sections of Annex C of ECMA-74.
- **Customer Usage Operating mode:** The operating mode is represented by the maximum of the steady state acoustical output at 100% of CPU TDP, 100% of Memory, 100% SSD, and 100% GPU load as the components showed in the above configurations.

# Rack, rails, and cable management

## Topics:

- [Rails information](#)

## Rails information



**Figure 10. System Information Label**

The rail offerings for the PowerEdge XE9685L consist of only one type which is stab-in sliding rail.

See the *Dell Enterprise Systems Rail Sizing and Rack Compatibility Matrix* available at [rail-rack-matrix](#) for information regarding:

- Specific details about rail types
- Rail adjustability ranges for various rack mounting flange types
- Rail depth with and without cable management accessories
- Rack types that are supported for various rack mounting flange types

Key factors governing proper rail selection include the following:

- Identifying the type of rack in which they will be installed.
- The spacing between the front and rear mounting flanges of the rack.
- The type and location of any equipment mounted in the back of the rack such as power distribution units (PDUs), and the overall depth of the rack
- Overall depth of the rack

## Stab-in, Sliding features summary

The Generic Tool-less stab-in sliding rail supports tool-less installation in 19" EIA-310-E compliant square hole and unthreaded round hole 4-post racks. It allows for the partial extension of the system out of the rack, enabling serviceability of key internal components.

### **B38 Stab-in sliding rails for 4-post racks**

- Supports stab-in installation of the chassis to the rails.
- Support for tool-less installation in 19" EIA-310-E compliant square, unthreaded round hole racks including all generations of the Dell racks. Also supports tool-less installation in threaded round hole 4-post racks.
- Support for tool-less installation in Dell Titan or Titan-D racks
- Support partial extension of the system out of the rack to allow serviceability of key internal components.

## Rack Installation

### Installing Stab-in Rails to the system

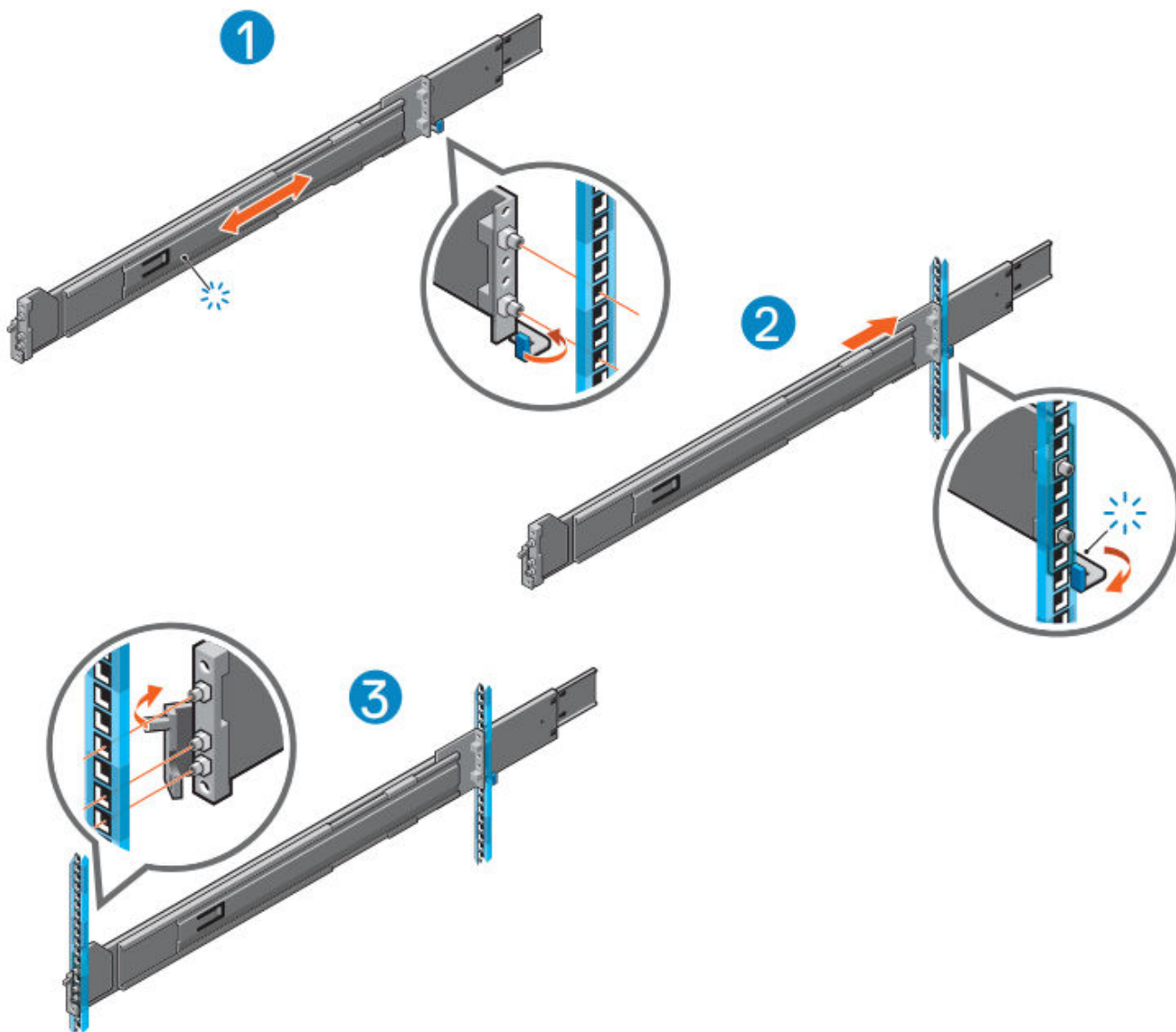
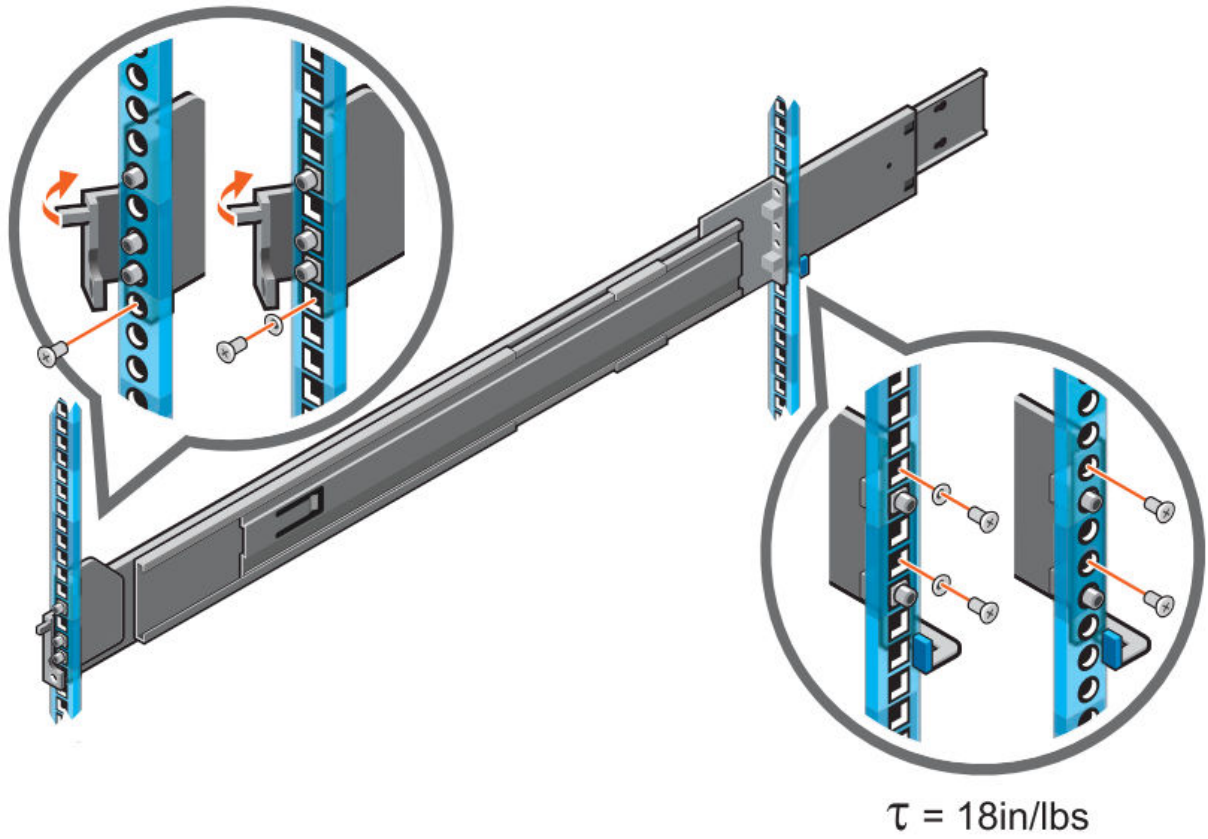

Figure 11. Installing the rail 4-POST racks



**Figure 12. Install the supplied hardware to secure rails for the rack level shipping**

**NOTE:** To secure the rails to square hole or unthreaded round hole rack for shipping or in unstable environments, install supplied hardware to the rails.

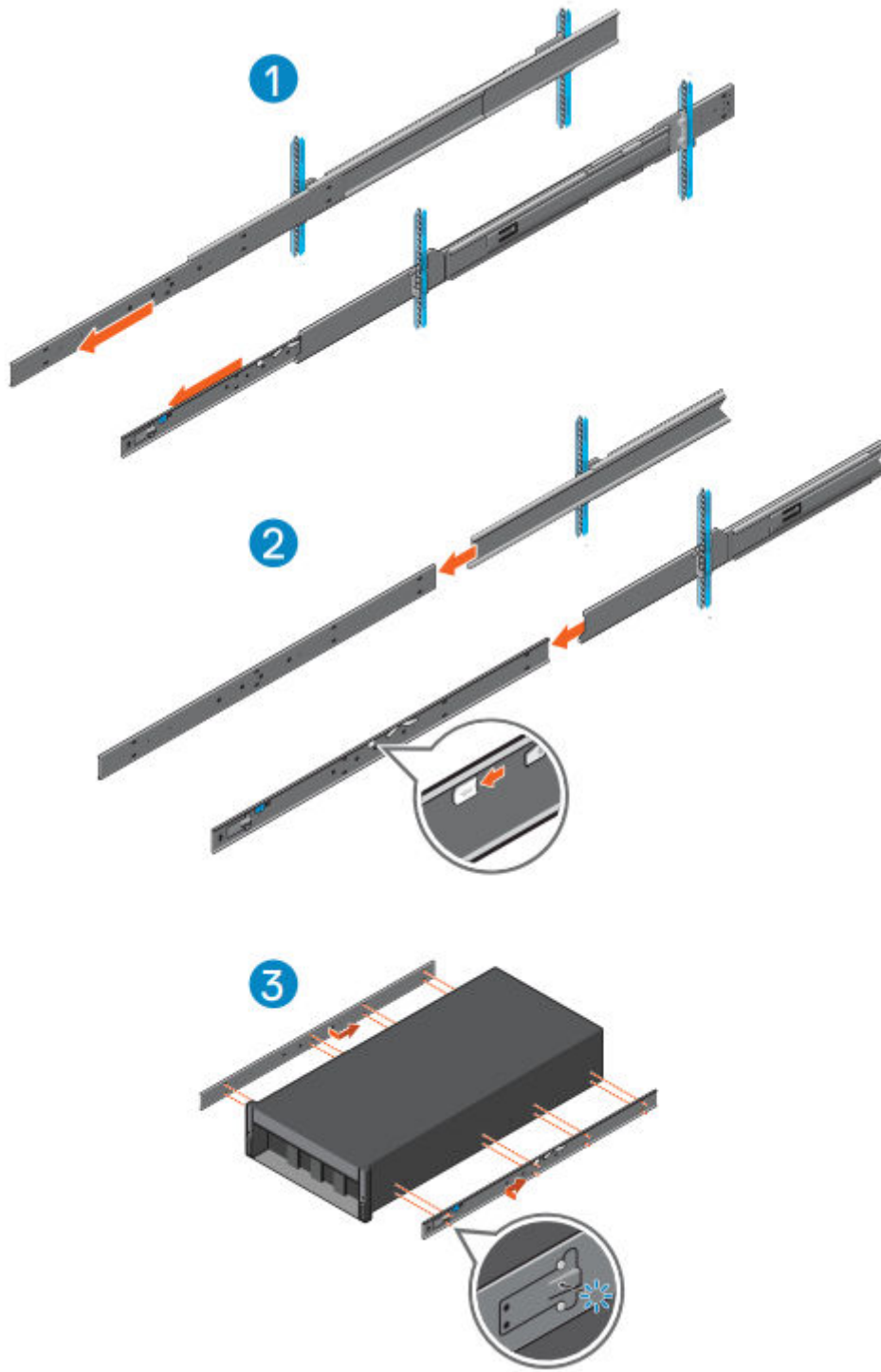
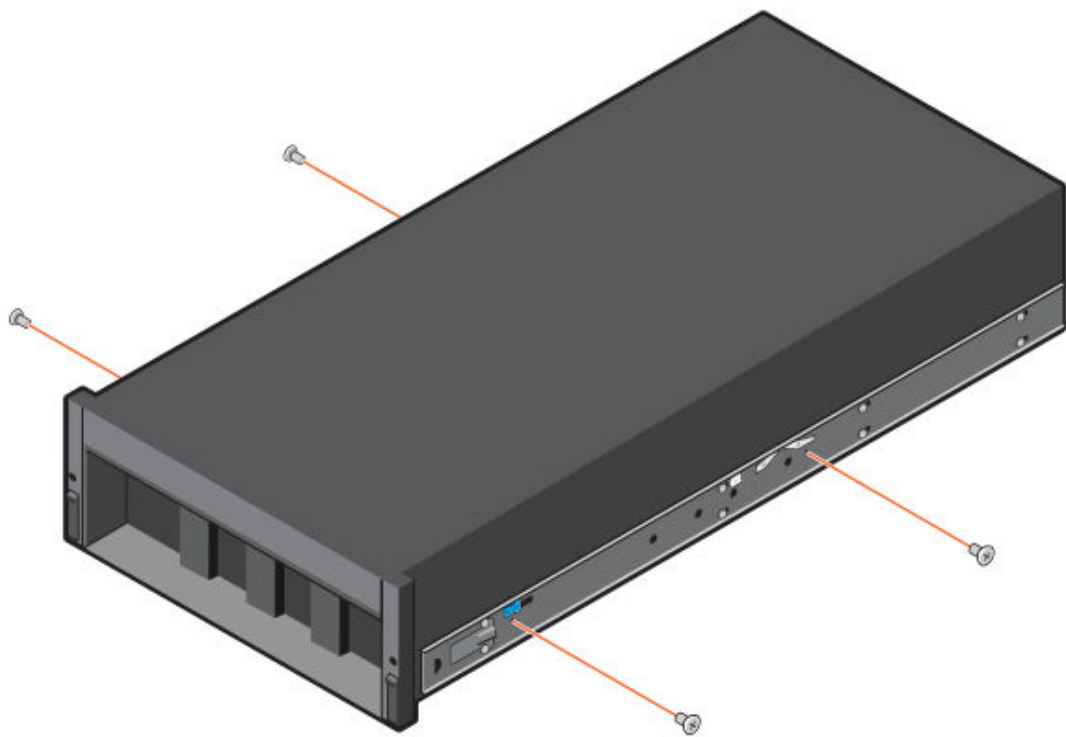

Figure 13. Install the stab-in rails to the system

4



**Figure 14. Shipping screws on the inner rails**

**NOTE:** For rack level shipping, the shipping screws must be installed on the inner rails.

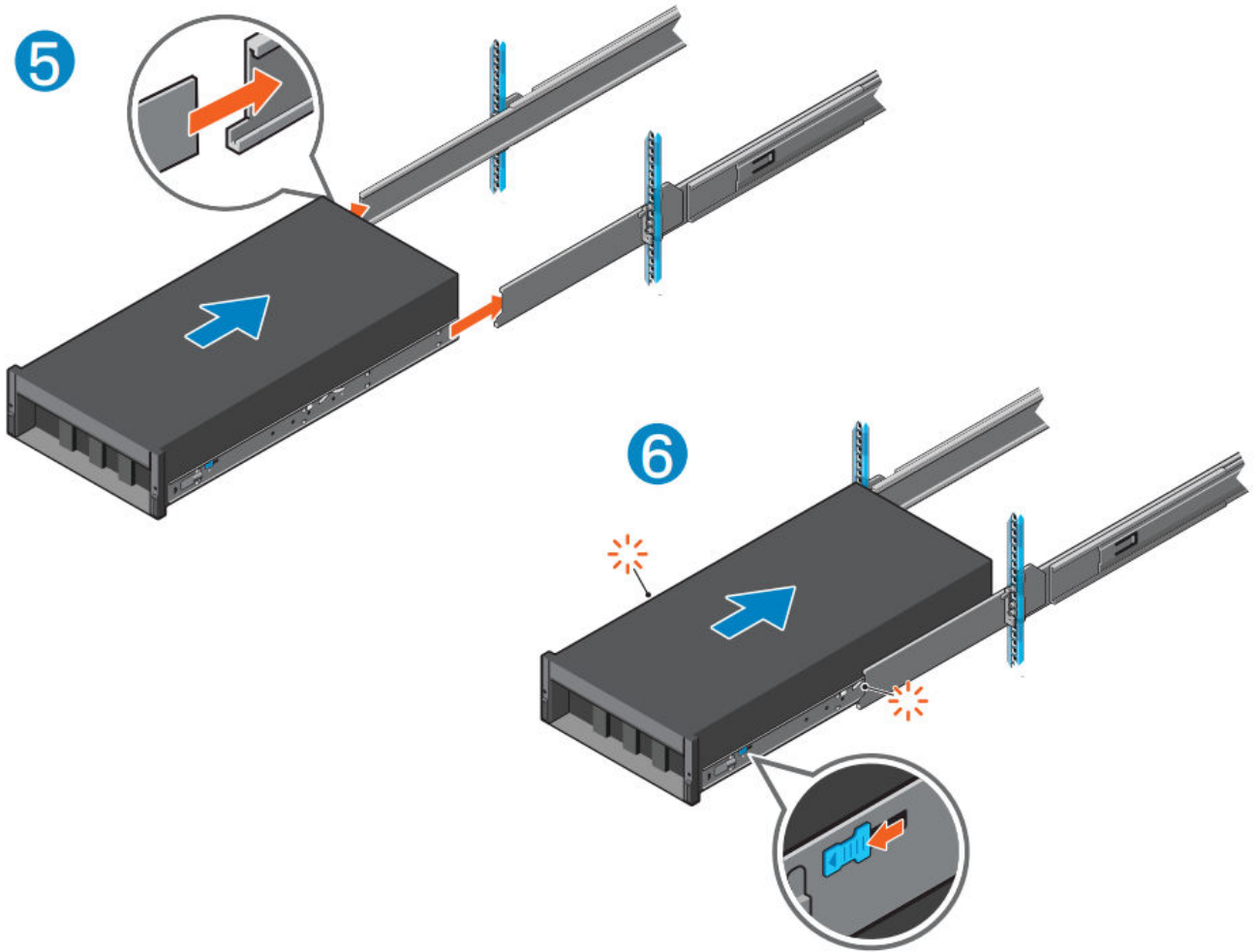

Figure 15. Install the stab-in rails to the system

**NOTE:** You can remove the system from the rails by performing the installation procedure in reverse order.

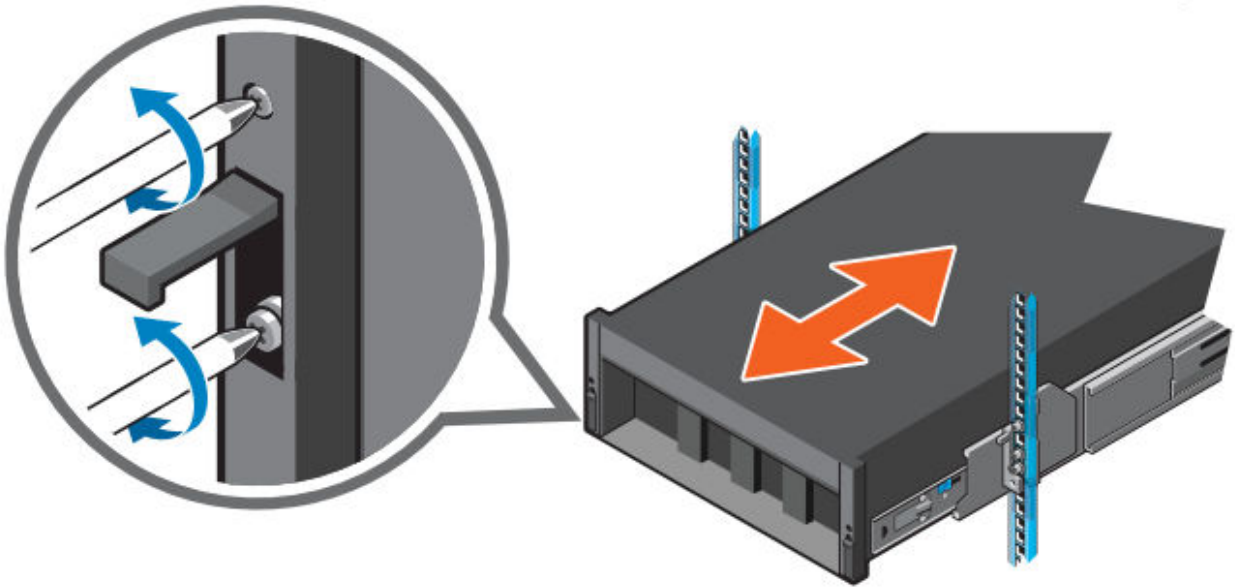

Figure 16. Securing or releasing the system to the rails

# Operating Systems and Virtualization

## Topics:

- [Supported operating systems](#)

## Supported operating systems

The PowerEdge XE9685L supports the following operating systems:

- Canonical Ubuntu Server LTS
- Red Hat Enterprise Linux

# Dell Systems Management

Dell delivers management solutions that help IT administrators effectively deploy, update, monitor, and manage IT assets. Dell solutions and tools enable you to quickly respond to problems by helping them to manage Dell servers efficiently; in physical, virtual, local, and remote environments; all without the need to install an agent in the operating system.

The OpenManage portfolio includes:

- Innovative embedded management tools - integrated Dell Remote Access Controller (iDRAC)
- Consoles - OpenManage Enterprise
- Extensible with plug-ins - OpenManage Power Manager
- Update tools - Repository Manager

Dell has developed comprehensive systems management solutions that are based on open standards and has integrated with management consoles from partners such as Microsoft and VMware, allowing advanced management of Dell servers. Dell management capabilities extend to offerings from the industry's top systems management vendors and frameworks such as Ansible, Splunk, and ServiceNow. OpenManage tools automate the full span of server life cycle management activities along with powerful RESTful APIs to script or integrate with your choice of frameworks.

For more information about the entire OpenManage portfolio, see:

- The latest [Dell Systems Management Overview Guide](#).

## Topics:

- [Integrated Dell Remote Access Controller \(iDRAC\)](#)
- [Systems Management software support matrix](#)

## Integrated Dell Remote Access Controller (iDRAC)

iDRAC9 delivers advanced, agent-free, local and remote server administration. Embedded in every PowerEdge server, iDRAC9 provides a secure means to automate a multitude of common management tasks. Because iDRAC is embedded within every PowerEdge server, there is no additional software to install; just plug in power and network cables, and iDRAC is ready to go. Even before installing an operating system (operating system) or hypervisor, IT administrators have a complete set of server management features at their fingertips.

With iDRAC9 in-place across the Dell PowerEdge portfolio, the same IT administration techniques and tools can be applied throughout. This consistent management platform allows easy scaling of PowerEdge servers as an organization's infrastructure grows. Customers can use the iDRAC RESTful API for the latest in scalable administration methods of PowerEdge servers. With this API, iDRAC enables support for the Redfish standard and enhances it with Dell extensions to optimize at-scale management of PowerEdge servers. By having iDRAC at the core, the entire OpenManage portfolio of Systems Management tools allows every customer to tailor an effective, affordable solution for any size environment.

Zero Touch Provisioning (ZTP) is embedded in iDRAC. ZTP - Zero Touch Provisioning is Intelligent Automation Dell's agent-free management puts IT administrators in control. Once a PowerEdge server is connected to power and networking, that system can be monitored and fully managed, whether you're standing in front of the server or remotely over a network. In fact, with no need for software agents, an IT administrator can: • Monitor • Manage • Update • Troubleshoot and remediate Dell servers. With features like zero-touch deployment and provisioning, iDRAC Group Manager, and System Lockdown, iDRAC9 is purpose-built to make server administration quick and easy. For those customers whose existing management platform utilizes in-band management, Dell does provide iDRAC Service Module, a lightweight service that can interact with both iDRAC9 and the host operating system to support legacy management platforms.

When ordered with DHCP enabled from the factory, PowerEdge servers can be automatically configured when they are initially powered up and connected to your network. This process uses profile-based configurations that ensure each server is configured per your specifications. This feature requires an iDRAC Enterprise license.

iDRAC9 offers following license tiers:

**Table 23. iDRAC9 license tiers**

License	Description
iDRAC9 Datacenter	<ul style="list-style-type: none"> <li>Available as an upsell on all servers</li> <li>Includes all features of Basic, Express, and Enterprise. Includes key features such as telemetry streaming, Thermal Manage, automated certificate management, and more</li> <li>Extended remote insight into server details, focused on high end server options, granular power, and thermal management</li> </ul>

For a full list of iDRAC features by license tier, see [Integrated Dell Remote Access Controller 9 User's Guide](#) at [Dell.com](#).

For more details on iDRAC9 including white papers and videos, see:

- [Support for Integrated Dell Remote Access Controller 9 \(iDRAC9\)](#) on the [Knowledge Base](#) page at [Dell.com](#)

## Systems Management software support matrix

**Table 24. Systems Management software support matrix**

Categories	Features	PE mainstream
Embedded Management and In-band Services	iDRAC9 (Express, Enterprise, and Datacenter licenses)	Supported
	OpenManage Mobile	Not Supported
	OM Server Administrator (OMSA)	Not Supported
	iDRAC Service Module (iSM)	Supported
	Driver Pack	Not Supported
Change Management	Update Tools (Repository Manager, DSU, Catalogs)	Supported
	Server Update Utility	Not Supported
	Lifecycle Controller Driver Pack	Supported
	Bootable ISO	Supported
Console and Plug-ins	OpenManage Enterprise	Supported
	Power Manager Plug-in	Supported
	Update Manager Plug-in	Supported
	SupportAssist Plug-in	Not Supported
	CloudIQ	Supported
Integrations and connections	OM Integration with VMware Vcenter/vROps	Not Supported
	OM Integration with Microsoft System Center (OMIMSC)	Not Supported
	Integrations with Microsoft System Center and Windows Admin Center (WAC)	Not Supported
	ServiceNow	Supported
	Ansible	Supported (post-RTS)
	Terraform Providers	Supported (post-RTS)
Security	Secure Enterprise Key Management	Supported
	Secure Component Verification	Supported
Standard operating system	Red Hat Enterprise Linux, SUSE, Ubuntu	Supported (Tier-1)

## Appendix A. Additional specifications

### Topics:

- Chassis dimensions
- System weight
- NIC port specifications
- Video specifications
- USB ports specifications
- PSU rating
- Environmental specifications

### Chassis dimensions

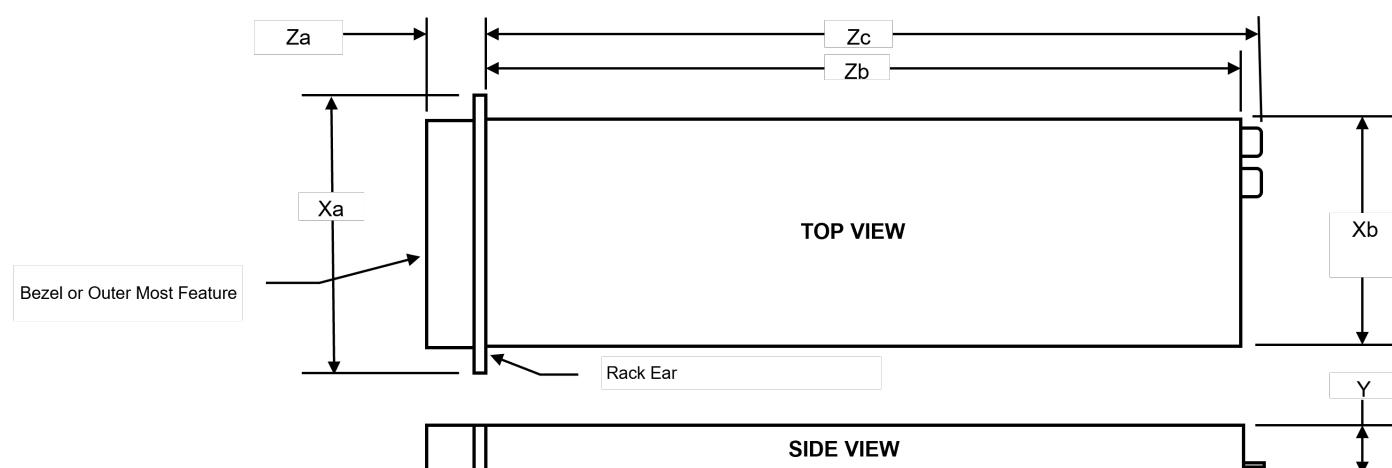

Figure 17. Chassis dimensions

Table 25. Chassis dimension for the PowerEdge XE9685L system

Drives	Xa	Xb	Y	Za (with bezel)	Za (without bezel)	Zb	Zc
8 x 2.5-inch SSDs + GPU	482 mm (18.97 inches)	Upper 2U: 447 mm (17.59 inches), Lower 2U: 434 mm (17.08 inches)	174.3 mm (6.86 inches)	35.67 mm (1.4 inches)	24.05 mm (0.94 inches)	966 mm (38.03 inches, top) Ear to rear wall	1001.57mm (39.43 inches) Ear to PSU handle

**NOTE:** Zb is the nominal rear wall external surface where the system board I/O connectors reside.

**NOTE:** Chassis length is longer than usual, need to consider potential interferences with the rear mounted PDU or the rear rack door when installed on rack.

# System weight

**Table 26. Weight for the PowerEdge XE9685L system with 8 x 2U SSDs**

System configuration	Maximum weight (with all drives/SSDs)
Fully populated XE9685L system	94.6 kg ( 208.55 pounds)

**Table 27. PowerEdge system weight handling recommendations**

Chassis weight	Description
40–70 pounds	Recommend two persons to lift.
70 pounds- 120 pounds	Recommend three persons to lift.
≥ 121 pounds	Recommend to use a server-lift.

- ⚠ **CAUTION:** The system is heavy and may slide, potentially causing damage when being installed or removed from a higher position on the rack.
- ⚠ **CAUTION:** It is recommended to always install PowerEdge XE9685L system from bottom of the rack under 24U (42", 106.7cm) to avoid damage. The system is heavy therefore can slide over and cause damage during installation and removal from a higher position on the rack.
- ⚠ **CAUTION:** Lift the system by using the provided lifting handles on chassis and refrain from using clips or other chassis points to lift the system. Non-designated lift-points on the chassis may cause system damage due to the inability to support the system weight while lifting.

# NIC port specifications

The PowerEdge XE9685L system supports up to two 10/100/1000 Mbps Network Interface Controller (NIC) ports embedded on the LAN on Motherboard (LOM) and integrated on the optional Open Compute Project (OCP) cards.

**Table 28. NIC port specification for the system**

Feature	Specifications
LOM card	1 GbE x 2
OCP card (OCP 3.0)	Broadcom 25 GbE x 2

# Video specifications

The system supports an integrated Matrox G200 graphics controller with 16 MB of video frame buffer.

**Table 29. Supported video resolution options for the system**

Resolution	Refresh rate (Hz)	Color depth (bits)
1024 x 768	60	8, 16, 32
1280 x 800	60	8, 16, 32
1280 x 1024	60	8, 16, 32
1360 x 768	60	8, 16, 32
1440 x 900	60	8, 16, 32
1600 x 900	60	8, 16, 32
1600 x 1200	60	8, 16, 32
1680 x 1050	60	8, 16, 32

**Table 29. Supported video resolution options for the system (continued)**

Resolution	Refresh rate (Hz)	Color depth (bits)
1920 x 1080	60	8, 16, 32
1920 x 1200	60	8, 16, 32

## USB ports specifications

**Table 30. PowerEdge XE9685L USB specifications**

Front		Rear	
USB port type	No. of ports	USB port type	No. of ports
USB 2.0-compliant port	One	USB 3.0-compliant port	One
iDRAC Direct port (Micro-AB USB 2.0-compliant port)	One	USB 2.0-compliant ports	One

**NOTE:** The micro USB 2.0 compliant port can only be used as an iDRAC Direct or a management port.

**NOTE:** Avoid connecting USB devices to the iDRAC Direct port of the PowerEdge XE9685L system during system initialization, POST, boot operations, or GPU firmware updates.

## PSU rating

Below table lists the power capacity of the PSUs in High/Low line operation mode.

**Table 31. PSUs Highline and Low line Ratings**

Features	3000 W Titanium
Peak Power (Highline/-72 VDC)	N/A
Highline/-72 VDC	N/A
Peak Power (Lowline/-40 VDC)	N/A
Lowline/-40 VDC	N/A
Highline 240 VDC	3000 W
DC-(48-60) V	N/A

The PowerEdge XE9685L supports six AC or DC power supplies.

Dell PSUs have achieved Titanium efficiency levels as shown in the table below.

**Table 32. PSU Efficiency Level**

Form Factor	Output	Class	10%	20%	50%	100%
Redundant 86mm	3000 W (Input 240AC)	Titanium	90.00%	94.00%	96.00%	94.00%

## Environmental specifications

**NOTE:** For additional information about environmental certifications, refer to the Product Environmental Datasheet located with the Manuals & Documents on [Dell Support](#).

**Table 33. Continuous operation specifications for ASHRAE A2**

Temperature	Specifications
Allowable continuous operations	
Temperature ranges for altitudes <= 900 m (<= 2953 ft)	10–35°C (50–95°F) with no direct sunlight on the equipment
Humidity percent ranges (non-condensing at all times)	8% RH with -12°C minimum dew point to 80% RH with 21°C (69.8°F) maximum dew point
Operational altitude de-rating	Maximum temperature is reduced by 1°C/300 m (1.8°F/984 Ft) above 900 m (2953 Ft)

**Table 34. Shared requirements across all categories**

Temperature	Specifications
Allowable continuous operations	
Maximum temperature gradient (applies to both operation and non-operation)	20°C in an hour* (36°F in an hour) and 5°C in 15 minutes (41°F in 15 minutes), 5°C in an hour* (41°F in an hour) for tape <i>i</i> <b>NOTE:</b> * - Per ASHRAE thermal guidelines for tape hardware, these are not instantaneous rates of temperature change.
Non-operational temperature limits	-40°C to 65°C (-104°F to 149°F)
Non-operational humidity limits	5% to 95% RH with 27°C (80.6°F) maximum dew point
Maximum non-operational altitude	12,000 meters (39,370 feet)
Maximum operational altitude	3,048 meters (10,000 feet)

**Table 35. Maximum vibration specifications**

Maximum vibration	Specifications
Operating	0.21 G <sub>rms</sub> at 5 Hz to 500 Hz (all operation orientations)
Storage	1.38 G <sub>rms</sub> at 7 Hz to 250 Hz for 15 minutes

**Table 36. Maximum shock pulse specifications**

Maximum shock pulse	Specifications
Operating	Six consecutively executed shock pulses in the positive and negative x, y, and z axis of 6 G for up to 11 ms.
Storage	Executed shock pulses in z axis (one pulse) of 71 G for up to 2ms

## Thermal restriction matrix

**Table 37. Thermal Restriction Matrix- 5<sup>th</sup> Generation AMD servers SKUs**

CPU (W)	Heat sink type	Fan Type	8 x 2.5-inch NVMe SSDs
			ASHRAE A2 (Max 35° C)
AMD CPU 9965/ 9755 (500W)	CPU coldplate	High-Performance Gold Fans (CPU Fan)	Supported
AMD CPU 9655/ 9575 (400W)			
AMD CPU 9455			

**Table 37. Thermal Restriction Matrix- 5<sup>th</sup> Generation AMD servers SKUs (continued)**

CPU (W)	Heat sink type	Fan Type	8 x 2.5-inch NVMe SSDs
			ASHRAE A2 (Max 35° C)
(300W)			

**Table 38. GPU/FPGA Thermal Restriction Matrix**

TDP (W)	Heat sink type	Fan Type	8 x 2.5-inch NVMe SSDs
			ASHRAE A2 (Max 35° C)
B200 8-GPU (1000 W per GPU)	GPU coldplate	High-Performance Gold Fans (GPU Fan)	Supported

Other restrictions:

- ASHRAE A3/A4 environments are not supported.
- Install a hard drive blank if the slot is not equipped with a hard drive.
- DIMM blank is not required when the DIMM population quantity is 12 pieces or more.

## Appendix B. Standards compliance

The system conforms to the following industry standards.

**Table 39. Industry standard documents**

Standard	URL for information and specifications
<b>ACPI</b> Advance Configuration and Power Interface Specification, v6.4	<a href="#">Specifications and Tools</a>
<b>Ethernet</b> IEEE Std 802.3-2022	<a href="#">IEEE Standards Association</a>
<b>IPMI</b> Intelligent Platform Management Interface, v2.0	<a href="#">IPMI</a>
<b>DDR5 Memory</b> DDR5 SDRAM Specification	<a href="#">DDR5 SDRAM</a>
<b>PCI Express</b> PCI Express Base Specification, v5.0	<a href="#">pciexpress</a>
<b>PMBus</b> Power System Management Protocol Specification, v1.2	<a href="#">PMBus specifications</a>
<b>SAS</b> Serial Attached SCSI, 3 (SAS-3) (T10/INCITS 519)	<a href="#">SCSI</a>
<b>SATA</b> Serial ATA Rev. 3.3	<a href="#">sata-io.org</a>
<b>SMBIOS</b> System Management BIOS Reference Specification, v3.3.0	<a href="#">DMTF SMBIOS</a>
<b>TPM</b> Trusted Platform Module Specification, v1.2 and v2.0	<a href="#">trustedcomputinggroup.org</a>
<b>UEFI</b> Unified Extensible Firmware Interface Specification, v2.7	<a href="#">uefi.org/specifications</a>
<b>PI</b> Platform Initialization Specification, v1.7	
<b>USB</b> Universal Serial Bus v2.0 and SuperSpeed v3.0 (USB 3.1 Gen1)	USB Implementers Forum, Inc. <a href="#">USB document library</a>
<b>NVMe</b> Express Base Specification. Revision 2.0c	<a href="#">NVMe specifications</a>
<b>NVMe</b> Command Set Specifications	
1. NVMe Express NVMe Command Set Specification. Revision 1.1c	
2. NVMe Express Zoned Namespaces Command Set. Revision 1.0c	
3. NVMe Express@ Key Value Command Set. Revision 1.0c	
<b>NVMe</b> Transport Specifications	
1. NVMe Express over PCIe Transport. Revision 1.0c	
2. NVMe Express RDMA Transport Revision. 1.0b	
3. NVMe Express TCP Transport. Revision 1.0c	
<b>NVMe</b> NVMe Express Management Interface. Revision 1.2c	
<b>NVMe</b> NVMe Boot Specification. Revision 1.0	

## Appendix C Additional resources

**Table 40. Additional resources**

Resource	Description of contents	Location
Installation and Service Manual	<p>This manual, available in PDF format, provides the following information:</p> <ul style="list-style-type: none"> <li>• Chassis features</li> <li>• System Setup program</li> <li>• System indicator codes</li> <li>• System BIOS</li> <li>• Remove and replace procedures</li> <li>• Diagnostics</li> <li>• Jumpers and connectors</li> </ul>	<a href="https://Dell.com/Support/Manuals">Dell.com/Support/Manuals</a>
Getting Started Guide	<p>This guide ships with the system, and is also available in PDF format. This guide provides the following information:</p> <ul style="list-style-type: none"> <li>• Initial setup steps</li> </ul>	<a href="https://Dell.com/Support/Manuals">Dell.com/Support/Manuals</a>
Rack Installation Guide	This document ships with the rack kits, and provides instructions for installing a server in a rack.	<a href="https://Dell.com/Support/Manuals">Dell.com/Support/Manuals</a>
System Information Label	The system information label documents the system board layout and system jumper settings. Text is minimized due to space limitations and translation considerations. The label size is standardized across platforms.	Inside the system chassis cover
QR code for system resources	This code on the chassis can be scanned by a phone application to access additional information and resources for the server, including videos, reference materials, service tag information, and Dell contact information.	Inside the system chassis cover
Enterprise Infrastructure Planning Tool (EIPT)	The Dell online EIPT enables easier and more meaningful estimates to help you determine the most efficient configuration possible. Use EIPT to calculate the power consumption of your hardware, power infrastructure, and storage.	<a href="https://Dell.com/calc">Dell.com/calc</a>

# Appendix D: Service and support

## Topics:

- Why attach service contracts
- ProSupport Infrastructure Suite
- Specialty Support Services
- ProDeploy Infrastructure Suite
- Supplemental Deployment Services
- Dell Technologies Consulting Services

## Why attach service contracts

Dell PowerEdge XE servers include a standard three-year hardware warranty covering repair or replacement of defective components. This warranty reflects the commitment to product quality but is limited to hardware-related issues and does not include software support. For extended warranty coverage and comprehensive support of both hardware and software, choose the ProSupport Infrastructure Suite.

## ProSupport Infrastructure Suite

Enterprise-class support that aligns with the criticality of your systems, the complexity of your environment, and how you allocate your IT resources. ProSupport Infrastructure Suite offers three service tiers: Basic Hardware Support, ProSupport for Infrastructure and ProSupport Plus for Infrastructure. These services extend hardware coverage, ensuring continued support beyond the standard warranty period. ProSupport and ProSupport Plus also address common software-related issues, ensuring comprehensive support for both hardware and software. ProSupport Plus offers enhanced capabilities, including support for third-party software, proactive system maintenance, and personalized guidance for performance optimization and other advanced needs. To ensure uninterrupted operation and optimal performance of Dell PowerEdge XE servers, it is recommended to evaluate and select the appropriate ProSupport Infrastructure Suite service based on the specific requirements of your environment.

	Basic Hardware Support	ProSupport	BEST ProSupport Plus
<b>Outcome Assistance and Advocacy</b> via assigned Technical Customer Success Manager ⓘ			
Enjoy a frictionless customer experience with cross-functional lifecycle management aligned to your goals			✓
Accelerate time-to-value through onboarding assistance, education and success planning			✓
Turn challenges into opportunities with actionable strategies powered by data and AI-driven analytics			✓
Ensure coverage continuity while preparing to scale for future success			✓
<b>Proactive Monitoring &amp; Actionable Insights</b> via Dell's connectivity solutions and tools			
Quickly visualize performance through a current system health score		✓	✓
Cybersecurity monitoring and mitigation recommendations provide another layer of protection		✓	✓
Predictive performance and capacity analysis address bottlenecks		✓	✓
Prevent or plan for downtime with predictive hardware anomaly detection		✓	✓
Energy consumption and carbon footprint forecasting support sustainability and stewardship initiatives		✓	✓
Get ahead of problems with proactive issue detection with automated case creation		✓	✓
Streamline internal IT efforts with efficient service request and escalation management tools	✓	✓	✓
Minimize disruptions by self-dispatching eligible parts	✓	✓	✓
<b>Support Essentials</b>			
Receive an assigned incident manager for Sev 1 issues who will work your issue through to resolution		✓	✓
Count on Mission Critical Support during Sev 1 incidents and natural disasters ⓘ			✓
Keep systems code current and performing at peak through Proactive System Maintenance			✓
Get priority access to senior technical support engineers—skip the queues and callbacks			✓
Bringing your own software? We provide limited 3rd party software support ⓘ			✓
Choose onsite parts delivery and labor response that meets your needs	Next Business Day	NBD or 4-hour	4-hour
Select product coverage that best augments your internal resources	Hardware	Hardware & Software	Hardware & Software
Have an issue? We are here for you by phone, chat and online	Local business hours	24/7/365	24/7/365

Figure 18. ProSupport Infrastructure Suite

## ProSupport Plus for Infrastructure

ProSupport Plus for Infrastructure is designed for customers who require proactive, predictive, and personalized support for business-critical systems. This service is ideal for environments managing essential applications and workloads where optimal performance and preventative maintenance are paramount. ProSupport Plus is recommended for PowerEdge XE servers to ensure comprehensive, preventative support for business-critical systems.

ProSupport Plus includes 4-hour onsite parts and labor response, all the features of ProSupport, and the following exclusive to ensure maximum uptime and system reliability:

1. **Priority Access to Senior Support Experts:** First in line access to Dell's most experienced support engineers for advanced troubleshooting and issue resolution.
2. **Mission Critical Support:** Rapid response and resolution for Severity 1 issues to minimize downtime and restore operations as quickly as possible.
3. **Technical Customer Success Manager (TCSM):** A dedicated advocate for cross-functional lifecycle management, advocacy, onboarding, and strategic planning throughout your technology journey.
4. **Proactive Systems Maintenance:** Semiannual updates to firmware, BIOS, and drivers to enhance system performance and availability.
5. **Third-Party Software Support:** Dell serves as a single point of accountability for eligible third-party software installed on ProSupport Plus systems, regardless of whether the software was purchased from Dell.

## ProSupport for Infrastructure

ProSupport for Infrastructure provides comprehensive 24x7x365 support for hardware and software, ideal for production workloads and applications that are important but not business-critical. ProSupport for Infrastructure is designed to keep your IT environment running smoothly with expert assistance and proactive solutions. This service ensures minimized disruptions and maximized availability of PowerEdge XE server workloads through:

- **24x7x365 Support:** Immediate remote support routing to the next available technician (no waiting for a call back), with 4-hour and Next Business Day onsite parts and labor dispatch options.
- **Broad, Centralized Support:** A single point of contact for hardware and software assistance, covering hypervisors, operating systems, applications, and eligible third-party software purchased from Dell and installed on ProSupport-covered servers.
- **Incident Management:** A dedicated Incident Manager for Severity 1 issues, collaborating with Dell experts and staying engaged until resolution.
- **Enhanced Proactive and Predictive Tools:** AI-driven anomaly detection, automated case creation followed by proactive outreach from Dell support, and infrastructure health/cybersecurity/energy monitoring via Dell AIOps and connectivity platforms.
- **Global Consistency:** A seamless support experience, regardless of location or language.

## Basic Hardware Support

Basic Hardware Support provides foundational support for hardware issues, including:

- Access to technical support during local business hours (phone, chat, online).
- Next Business Day (NBD) onsite parts and labor response.
- Hardware troubleshooting only (no software troubleshooting, unless it's to confirm hardware functionality).
- Proactive automated issue detection and automated case creation if the system is connected (customer receives notification and must contact Dell to proceed; unattended queue approach).

## Specialty Support Services

Optional specialty support services complement the ProSupport Infrastructure Suite to provide additional expertise that are critical for modern data center operations.

## Hardware coverage add-ons to ProSupport or ProSupport Plus

- **Keep Your Hard Drive (KYHD), Keep Your Component (KYC), or Keep Your GPU (KYGPU):**

Normally if a device fails under warranty, Dell replaces it using a one-for-one exchange process. KYHD/KYCC/KYGPU gives you the option to retain your device. It provides full control of sensitive data and minimizes security risk by letting you retain possession of failed drives, components, or GPU when receiving replacement parts without incurring additional cost.

- **Onsite Diagnosis Service:**

Ideal for sites with non-technical staff. A Dell certified field technician performs initial troubleshooting diagnosis onsite and collaborates with remote Dell support engineers to resolve the issue. Customers can request dispatch of an onsite technician at any time for any severity support incident.

- **ProSupport Add-on for HPC (High Performance Computing):**

The ProSupport Add-on for HPC enhances a ProSupport Infrastructure Suite service contract by providing solution-aware support tailored to the unique needs of maintaining an HPC environment. Key features include:

- Access to Senior HPC Experts: Direct support from specialists with deep expertise in HPC systems.
- Advanced HPC Cluster Assistance: Guidance on performance optimization, interoperability, and configuration.
- Enhanced End-to-End Support: Comprehensive solution-level support for HPC environments.
- Remote Pre-Support Engagement: Collaboration with HPC specialists during deployment implementation to ensure a smooth setup process.

- **Carrier-Grade Support:**

Carrier-Grade Support service is designed for leading global telecommunications customers. It offers direct access to Dell solution experts specializing in telecommunications applications and outcomes. This service includes a hardware uptime guarantee, ensuring system restoration within 4 hours for Severity 1 issues. If service-level agreements (SLAs) are not met, Dell assumes penalties and fees, reinforcing its commitment to reliability and performance.

## Personalized support and supplemental infrastructure expertise

- **Technical Account Manager (TAM):** The Dell TAM service provides a designated technology expert who monitors and manages the performance and configuration of specific technology sets. TAMs strive to gain deep knowledge of your environment and business goals in order to deliver recommendations for Dell solutions that optimize IT performance and resilience.
- **Designated Support Engineer (DSE):** The Dell DSE service provides an assigned technical expert that delivers personalized, hands-on troubleshooting expertise. Acting as your direct point of contact for all support needs, our DSEs ensure swift problem resolution, real-time communication and tailored recommendations to help you maintain a resilient and efficient IT environment.
- **Multivendor Support Service (MVS):** Support your non-Dell infrastructure devices under one support contract serviced by Dell. An MVS support contract can include coverage for Broadcom, Cisco, Fujitsu, HPE, Hitachi, Huawei, IBM, Lenovo, NetApp, Oracle, Quanta, Supermicro and others.

## Services for Large Enterprises

- **ProSupport One for Data Center:**

ProSupport One for Data Center is designed to deliver scalable, efficient, and reliable support for complex IT environments. ProSupport One for Data Center is available for large and distributed data centers with over 1,000 assets (including servers, storage, data protection, and networking devices) or a significant investment in Dell storage and HCI products. Built on the foundation of ProSupport, this support offer is designed for Dell's largest customers, enabling them to customize a support solution that meets their unique hardware and software needs. Key benefits include:

- **Customized Support:** Tailor support services to address unique data center environments and existing IT systems and capabilities.
- **Cost-Effective Options:** Choose support that aligns with technical support consumption and budget, optimizing investments while maintaining required service levels.
- **Resource Augmentation:** Add a Technical Account Manager (TAM) or Designated Support Engineer (DSE) to augment your team. TAMs provide advanced knowledge and advice to help customers realize maximum value from their enterprise investments and the DSE is a designated product-focused troubleshooting expert who understands the environment to enhance overall health.
- **Enhanced Infrastructure Management:** Leverage advanced automation, real-time infrastructure monitoring, and AI-powered analytics to streamline operations, reduce risks, and minimize downtime.

- **Onsite Parts Service (OPS)**

Ideal for large organizations that have their own staff to support their data center, OPS enables Dell and the customer to collaboratively manage parts inventory located at the customer's designated facility. Dell Logistics Online Inventory Solution (LOIS) software program is used to monitor and automate replenishment of inventory in the customer's onsite parts locker. As a replacement part is scanned out of inventory for use, the LOIS software automatically initiates a replenishment order with Dell that is either shipped the next day or delivered onsite by Dell during a scheduled onsite service visit. LOIS also allows customers to integrate their inventory system directly to Dell TechDirect using APIs to further streamline the support and parts management processes.

## End-of-Life Services

- **Asset Recovery Services** are available on infrastructure products such as servers, storage and networking assets. The service provides secure disposition, regulatory compliance, value recovery, and environmental reporting—helping customers retire IT infrastructure with confidence while supporting sustainability goals.
- **Data Sanitization & Data Destruction** services render data unrecoverable on repurposed or retired products such as servers, storage and data protection hardware. Data Sanitization is performed according to NIST SP 800-88 r1 guidelines which ensures complete and irreversible removal of sensitive data from devices. When erasure is not feasible, Data Destruction services provide physical destruction of hard drives. All activities are documented, with detailed compliance reports provided for both data sanitization and data destruction outcomes—helping organizations retire infrastructure assets safely and in alignment with regulatory expectations.

## ProDeploy Infrastructure Suite

### ProDeploy Flex for factory rack integration and cluster services

For small or large opportunities desiring preconfigured servers and/or networking delivered in fully or partially populated racks, our services for AI infrastructure deployment deliver end-to-end, rack-scale deployment and validation for PowerEdge XE platforms paired with options for AI networking. These services include factory rack integration (L11), cluster build (L12), and acceptance testing to ensure Day-1 readiness and peak performance for AI workloads.

- Infrastructure Readiness Assessment to evaluate the data center prior to an AI deployment to include: datacenter layout, power/cooling (including liquid cooling), cabling, airflow, and site logistics.
- Factory rack integration (L11) of advanced PowerEdge XE servers integrated with NVIDIA InfiniBand switches or Ethernet options from Dell or NVIDIA are put through a set of strenuous tests to validate functionality of the solution prior to shipping.
- Rack placement, power connectivity, and liquid-cooling connectivity if applicable.
- Cluster build (L12) turns multiple integrated racks into a high-performance cluster: deploy all inter-rack cabling, configure the AI fabric, validate cluster, and perform acceptance testing.
- Knowledge transfer and project documentation to equip your team for Day-2 operations and ongoing improvements.

ProDeploy Flex for factory rack integration is the most effective method to deploy rack solutions and optimize at scale.

### ProDeploy Plus for onsite builds

For smaller quantity solutions that don't require factory rack integration, ProDeploy Plus is ideal. This service provides expert onsite installation and configuration for complex PowerEdge XE platforms. All implementations are performed by Dell-badged employees, not 3<sup>rd</sup> parties, to ensure the utmost care and expertise is maintained through the entire process.

- Accelerate time to value with Dell engineers, site readiness and implementation planning, full onsite software installation and configuration, and validation prior to handoff.
- Proven speed: up to 3x faster planning and deployment versus in house admins with the ProDeploy Infrastructure Suite.
- Ideal for smaller XE deployments or unique proof-of-concept racks when factory services are not being used; complements rack integration for larger, rack scale AI builds.
- Reduce risk on GPU dense systems with Dell's specialized XE deployment practices and testing rigor built for AI servers.

# Supplemental Deployment Services

Additional ways to expand scope or deploy for unique scenarios.

## Residency Services

Certified technical professionals act like an extension of your IT staff to enhance internal capabilities and resources and help you realize faster adoption and maximized ROI of new technology. Residency Services help customers transition to new capabilities quickly by leveraging specific technology skill sets. Residency experts can provide post implementation management and knowledge transfer that is related to a new technology acquisition or day-to-day operational management of the IT infrastructure.

- Global experts available to serve in-person (onsite) or virtual (remote).
- Engagements starting at 2 weeks with flexibility to adjust.
- Residency is available for project management needs, and many different technology skills sets such as: AI expertise, compute, storage, networking, security, multi-cloud, data management, and modern workforce applications.

## Additional Deployment Time (ADT)

You can expand the scope of a ProDeploy engagement leveraging Additional Deployment Time (ADT). ADT covers additional non-complex tasks beyond the usual quantity of deliverables of the ProDeploy offers. ADT can also be used as a standalone service without ProDeploy, to accomplish tasks related to Project Management or Technical Resource Expertise. ADT is sold in blocks of four hours remote or eight hours onsite. The Dell delivery team can help scope the number of hours required for specific customer needs.

## Data Migration Services

Migrating data sets is no easy task. Our experts use proven tools and processes to streamline data migrations and avoid compromising data. A customer project manager works with our experienced team of experts to create a migration plan. Data migration is part of every technology upgrade, platform change, and shift to the cloud. You can rely on Dell data migration services to perform a seamless transition while our customers can keep their focus on their core business.

## DAY 2 – Automation Services with Ansible

Dell solutions are built as “automation ready” with integrated APIs (Application Programming Interfaces) to allow customers to programmatically call actions on the product through code. Although Dell has published Ansible automation use cases, some customers need additional assistance with GitOps. By the end of the service, the customer will have the foundational components required to accelerate automation and understand how the programming works together: Day 1 and Day 2 use case automation scripts (ansible modules), CI/CD tool (Jenkins), and Version control (Git).

# Dell Technologies Consulting Services

## Accelerate Modernization Initiatives with Dell Consulting

When it comes to your IT and business goals, there are a ton of possible initiatives you can focus on and problems you can solve. But it can be confusing and complex when deciding what you should prioritize for your organization and where to start. The experts at Dell Technologies Consulting Services help you harmonize your business and IT needs with our outcome-focused approach. From strategy to full-scale implementation, we can deliver more, faster, so you and your organization can get back to innovating. We listen to and understand your unique needs, then collaborate with you to help you deliver the most value to your business. With decades of expertise and repeatable, proven processes, you get consistent outcomes and accelerated time-to-value. All with a holistic approach to your business outcomes. So whether you're looking to deliver cloud platforms, workforce experiences, data and applications, or achieve a resilient security posture for your business, you can be confident that your organization is heading in the right direction with Dell.

The first step: Half-day workshops.

Identify priorities to build your digital future. Our facilitated workshop discussions focus on the activities required to achieve your desired end state and conclude with next steps to further advance your business and IT strategies.

Available workshops: AI, Multicloud, Apps & Data, Modern Workforce, Security & Resiliency.

## Dell Managed Services

Some customers prefer Dell to manage the complexity and risk of daily IT operations, Dell Managed Services utilizes proactive, AI enabled delivery operations and modern automation to help customers realize desired business outcomes from their infrastructure investments. With these technologies, our experts run, update, and fine-tune customer environments that are aligned with service levels, while providing environment-wide and down-to-the-device visibility. There are two types of managed service offers. First the outsourcing model or CAPEX model where Dell manages the customer owned assets using our people and tools. The second is the as-a-Service model or OPEX model called APEX. In this service, Dell owns all technology and all the management of it. Many customers will have a blend of the two management types depending on the goals of the organization.

## Cyber-Security Services

### Managed Detection and Response (MDR)

Dell Managed Detection and Response Pro Plus is our fully-managed, 360° security operations solution comprised of our most cutting-edge, preventive and responsive cybersecurity services. MDR Pro Plus was designed with your top security concerns in mind, allowing you to focus on your core business goals while Dell handles your security operations. First, we have Vulnerability Management. With this service, we'll do ongoing scanning of the customer's environment looking for software that needs to be patched. Next is Pen Testing and Attack Simulation Management. This service will continuously validate security controls and policies with automated Breach and Attack Simulation (BAS), because a misconfiguration can lead to an exposure which an attacker can exploit. The service also includes an annual penetration test to determine if a skilled threat actor could exploit pathways leading to critical assets or data. Third, Managed Security Awareness Training. This service will educate the customer's end users so that they don't inadvertently put the customer at risk. If you think about our annual compliance training modules, there is always a security module. This is the same type of thing, but rather than once a year, it will be smaller, bite-size pieces of content delivered throughout the year. Fourth is our Managed Detection and Response service which provides 24x7 threat detection and investigation, analysis of end-to-end activity by threat actors, threat hunting, and quick initiation of cyber incident response when needed. Customers can choose between SecureWorks Taegis XDR, CrowdStrike Falcon XDR or Microsoft Defender XDR as the security analytics platform our analysts will use to monitor their environment. All four of these services are delivered by experienced, certified Dell security experts using advanced technology such as the SecureWorks Taegis XDR, CrowdStrike Falcon XDR or Microsoft Defender XDR security platforms.

## Dell Technologies Education Services

Build the IT skills required to influence the transformational outcomes of the business. Enable talent and empower teams with the right skills to lead and perform transformational strategy that drives competitive advantage. Leverage the training and certification that is required for real transformation.

Dell Technologies Learning Services offers training and certifications that are designed to help customers achieve more from their hardware investment. To learn more or register for a class today, see [learning.dell.com](https://learning.dell.com).